

Rail Industry Standard
RIS-0703-CCS
Issue: 2 Draft: draft 0.7
Date: September 2023

Signalling Layout and Signal Aspect Sequence Requirements

Synopsis

This document sets out requirements for the lineside signalling system to be compatible with train operations and guidance on their application.

Copyright in the Railway Group documents is owned by Rail Safety and Standards Board Limited. All rights are hereby reserved. No Railway Group document (in whole or in part) may be reproduced, stored in a retrieval system, or transmitted, in any form or means, without the prior written permission of Rail Safety and Standards Board Limited, or as expressly permitted by law.

RSSB members are granted copyright licence in accordance with the Constitution Agreement relating to Rail Safety and Standards Board Limited.

In circumstances where Rail Safety and Standards Board Limited has granted a particular person or organisation permission to copy extracts from Railway Group documents, Rail Safety and Standards Board Limited accepts no responsibility for, nor any liability in connection with, the use of such extracts, or any claims arising therefrom. This disclaimer applies to all forms of media in which extracts from Railway Group documents may be reproduced.

Published by RSSB

Issue Record

Issue	Date	Comments
1	03/03/2018	Original document setting out requirements, rationale and guidance for signalling layout and signal aspect sequences that are used to implement a signalling layout that is driveable.
1.1	13/03/2018	This document has been reissued to correct formatting only. There are no changes to the content.
2	September 2023	<p>Updated to address the recommendations from the 12-month review of issue 1.1 and enable Network Rail to withdraw a company standard on colour light junction signalling. Key changes include:</p> <ul style="list-style-type: none"> • Editorial changes throughout to clarify the intent of requirements and guidance. • Part 1: Introductory guidance updated; rationales reviewed and summarised • Part 2: Movement authority (MA) terminology changed to include 'Full MA' and 'On-sight MA'. Requirements for lamp proving withdrawn and replaced by guidance describing good practice in mitigating risk of failure • Part 3: Additional guidance setting out good practice in the application of colour light junction signalling and enable the withdrawal of a Network Rail company standard. Updated requirements and guidance on application of preliminary route indicators and banner junction indicators • Updated definitions and cross references

Revisions are highlighted by revision bars in the left hand margin

Superseded documents

The following Railway Group documents are superseded as indicated:

Signalling Layout and Signal Aspect Sequence Requirements

Rail Industry Standard
RIS-0703-CCS
Issue: 2 Draft: draft 0.7
Date: September 2023

Superseded documents	Sections superseded	Date when sections are superseded
RIS-0703-CCS issue 1.1	All	September 2023

Supply

The authoritative version of this document is available at www.rssb.co.uk/standards-catalogue.
Enquiries on this document can be submitted through the RSSB Customer Self-Service Portal <https://customer-portal.rssb.co.uk/>

Contents

Section	Description	Page
Part 1	Purpose and Introduction	8
1.1	Purpose	8
1.2	Application of this document	8
1.3	Introduction	8
1.4	Health and safety responsibilities	11
1.5	Structure of this document	11
1.6	Approval and Authorisation	11
Part 2	Requirements for Movement Authorities	12
2.1	Providing signalled MAs	12
2.2	Requirements for stop signals	19
2.3	Requirements for indicating the limit of MA (stop aspects)	25
2.4	Requirements for shunt MAs (shunt aspects)	26
2.5	Requirement for on-sight MAs and shunt MAs	28
2.6	Requirements for degraded MAs (PoSA aspects)	32
2.7	Requirements for main proceed aspects	34
2.8	Requirements for cautionary aspect sequences on TCB lines	37
2.9	Requirements for cautionary aspect sequences on non-TCB lines	46
Part 3	Requirements for Indication of Route	50
3.1	Requirements to indicate which line the MA applies to	50
3.2	Requirements for indication of route with a shunt MA	55
3.3	Route-ing information with an on-sight MA	57
3.4	Requirements for indication of route with a main proceed aspect	58
3.5	Requirements for preliminary route indicators	65
3.6	Requirements for junction aspect sequences	68
3.7	Requirements for junction aspect sequence: MAR	73
3.8	Junction aspect sequence: MAF	75
3.9	Requirements for junction aspect sequences: MAY-FA3 & MAY-FA4	76
3.10	Requirements for junction aspect sequence: MAY-YY	81
3.11	Requirements for junction aspect sequence: MAF-SD	84
Part 4	Requirements for System Status Indications	91
4.1	Requirements for signal OFF indications	91
4.2	Requirements for locally monitored infrastructure indications	92
4.3	Requirements for facing points indications	93

Signalling Layout and Signal Aspect Sequence Requirements

Rail Industry Standard
RIS-0703-CCS
Issue: 2 Draft: draft 0.7
Date: September 2023

4.4	Requirement for level crossing operating indications	96
4.5	Requirements for barriers up (BU) indication	96
4.6	Requirements for TPWS indications	97
4.7	Requirements for mechanical trip-cock system indications	99
<hr/>		
Part 5	Requirements for Train Operating Indications	100
5.1	Requirement for signs that present written instructions	100
5.2	Requirements for train dispatch system indications	100
5.3	Requirements for loading / unloading indications	101
<hr/>		
Definitions		103
<hr/>		
References		108

List of Figures

Figure 1: Example of a preset shunt signal	24
Figure 2: Example of a preceding shunt signal	25
Figure 3: Example of a 3-aspect to 4-aspect transition omitting a main stop aspect	39
Figure 4: Example of a 3-aspect to 4-aspect transition with excess signal spacing	39
Figure 5: Example of applying an approach release from red control at a 3-aspect to 4-aspect transition	40
Figure 6: A 4-aspect to 3-aspect signalling transition at a diverging junction	41
Figure 7: An example of a 3-aspect sequence presented by colour light signals	42
Figure 8: An example of a 4-aspect sequence	43
Figure 9: An example showing a 4-aspect sequence that omits the YY aspect for trains starting from a bay platform	45
Figure 10: Example of indicating alternative paths using different types of route indications	62
Figure 11: Example of indicating alternative paths using alphanumeric route indications	63
Figure 12: Example of a PRI on the approach to a junction signal	67
Figure 13: A typical MAY-FA3 aspect sequence for a right hand diverging junction	79
Figure 14: A typical MAY-FA4 aspect sequence for a right hand diverging junction	80
Figure 15: A typical MAY-YY aspect sequence	84
Figure 16: Splitting distant signal positioned on the left-hand side of the line with a left-hand diverging junction	86
Figure 17: Splitting distant signal positioned on the right-hand side of the line with a left-hand diverging junction	87
Figure 18: Splitting distant signal positioned on the left-hand side of the line with a right-hand diverging junction	88
Figure 19: A typical MAF-SD4 aspect sequence for a right hand diverging route	90
Figure 20: A typical sequence of indications at locally monitored facing points	96

List of Tables

Table 1: Types of MA, signal route classes and signal aspects	13
Table 2: Junction aspect sequences	68
Table 3: Permitted junction approach aspect sequences at the same junction	71
Table 4: Permissible speed profiles typically applied to MAY-FA3 and MAY-FA4	77

Part 1 Purpose and Introduction

1.1 Purpose

- 1.1.1 This document sets out the requirements and guidance on the layout of lineside signalling assets and signal aspect sequences.
- 1.1.2 These requirements can be used when applying the Common Safety Method for Risk Evaluation and Assessment (CSM RA) risk acceptance principles to control the hazard of poor driveability.
- 1.1.3 The requirements in this standard do not take account of all hazards that may arise on lines fitted with a lineside signalling system when trains are operated using a cab signalling system, for example ERTMS/ETCS.
- 1.1.4 This document can be adopted by infrastructure managers under their respective safety management system or when specifying products and services.

1.2 Application of this document

- 1.2.1 Compliance requirements and dates have not been specified because these are the subject of internal procedures or contract conditions.
- 1.2.2 If you plan to do something that does not comply with a requirement in this RIS, you can ask a Standards Committee to comment on your proposed alternative. If you want a Standards Committee to do this, please submit your deviation application form to RSSB. You can find advice and guidance on using alternative requirements on RSSB's website www.rssb.co.uk.

1.3 Introduction

How to use the requirements in this document

- 1.3.1 This document sets out requirements for the features of lineside signalling systems that support safe integration with train operations and guidance on their application. These requirements are underpinned by an analysis of the signal engineering practices applicable to the Great Britain (GB) mainline railway to understand how they control the factors that support and influence driveability.
- 1.3.2 The requirements in this document can be applied, in conjunction with a risk assessment, to control the following hazard precursors and inform a decision on whether the lineside signalling system is driveable:
 - Necessary MA information is not provided by the signalling system
 - Information provided by the signalling system is not complete
 - Some provided information is not current
 - Provided information is not relevant to some trains
 - Provided information cannot be relied upon
 - Poor accuracy of the provided information
 - Poor readability
 - Poor interpretability

- Inconsistent signal aspects and indications presented along the line
- Inconsistent infrastructure location of one or more signalling assets
- Information is provided at inconsistent times
- Insufficient time for the train driver to comply with the operating requirement
- Excessive time for the train driver to comply with the operating requirement.

1.3.3 Further guidance on the hazard precursors and applying the driveability assessment process to lineside signalling systems is set out in RIS-0713-CCS.

1.3.4 Some existing railway infrastructure is fitted with a lineside signalling system design that does not fully conform with the requirements in this document. When planning a change to a legacy lineside signalling system, it is good practice to evaluate the cost-benefit and feasibility of bringing the signalling system into compliance with this standard. Driveability assessment and risk assessment are used to confirm safe integration of the selected option.

Driveability

1.3.5 A well-designed signalling system supports safe integration with train driving (driveability). This means that train drivers can obtain and use the information provided by lineside signals, indicators and signs to take good train driving decisions. A definition of driveability is provided in [page 103](#).

1.3.6 A well-designed signalling system implements features that support the control of risks, enable train performance and optimise infrastructure capacity.

1.3.7 A signalling system that has poor driveability is a hazard which, if uncontrolled, could result in unacceptable safety risk. This includes the collision risk or derailment risk that can arise when a train:

- a) Exceeds a limit of movement authority (MA)
- b) Exceeds a permissible speed limit
- c) Uses an on-sight MA incorrectly
- d) Occupies a level crossing area when a road user is present
- e) Uses locally monitored infrastructure that is not correctly set for the train movement
- f) Starts to move before the 'right away' is given.

1.3.8 Driveability has a range; it is influenced by the operational context on each route where the trains will be driven and therefore changes to a lineside signalling system are assessed before they are put into use. The contribution of a lineside signalling system to driveability is to 'be driveable'. Other contributions to driveability include the signalling operations and train driving processes.

1.3.9 Train driving involves a continuous process, which includes:

- a) Monitoring the railway environment
- b) Gathering and assimilating the information needed, including reading and interpreting information presented at the lineside, in the cab, from other people and using procedures
- c) Taking decisions based on all the information available

- d) Controlling the train to maintain the required speed, including starting, stopping, accelerating and braking.
- 1.3.10 The lineside signalling system provides the following types of information applicable to the train driving processes:
- a) MA
 - b) Route-ing
 - c) Locally monitored system status (for example, 'points correctly set')
 - d) Operating instruction (for example, 'close train doors')
 - e) Permissible speed limit change.
- 1.3.11 Other information relevant to train driving is provided by authorised personnel (for example, signallers and station staff), working timetables, rules and procedures.
- 1.3.12 The design of the lineside signalling system influences:
- a) What information is provided by the lineside signalling system
 - b) Which signal aspects, indications and signs provide the information
 - c) Where the information is positioned within the driver's field of vision
 - d) When the information is provided relative to the required train driving response.
- 1.3.13 Train drivers read and interpret signal aspects, indications and signs in order to understand:
- a) Whether or not an MA is provided to the train
 - b) The type and extent of MA that is provided
 - c) Which route is set at a diverging junction and, therefore, which applicable permissible speed applies
 - d) The operational status of locally monitored systems on the route
 - e) Relevant train operating instructions
 - f) The permissible speed limit.
- 1.3.14 Providing a lineside signalling system that is driveable does not mean that the risk is reduced to an acceptable level - further risk controls are implemented using a train protection system; for example, AWS/TPWS. Risk assessment is used to confirm that sufficient risk controls are provided.
- 1.3.15 Further requirements and guidance on risk controls and risk assessment are provided in rail industry standards (RISs) and company standards published by the infrastructure manager.
- 1.3.16 Further requirements and guidance on operating the signalling system and train operations are provided in the National Operating Publications and the safety management systems implemented by infrastructure managers and railway undertakings.
- Relevant requirements and guidance in other Railway Group documents**
- 1.3.17 GEGN8651 provides guidance on using standards to inform decisions about safe integration of changes to lineside signalling systems into the GB mainline railway.

- 1.3.18 The following standards set out requirements applicable to lineside signalling systems:
- a) GKRT0057 sets out requirements for lineside signalling equipment so that is capable of being readable when used as intended
 - b) GKRT0075 specifies the minimum signalling braking distance (MSBD) data used for lineside signal spacing
 - c) RIS-0036-CCS sets out the requirements for transitions to and from lineside signalling systems
 - d) RIS-0386-CCS sets out the requirements for signal overrun risk assessment
 - e) RIS-0713-CCS sets out the requirements for the driveability assessment of lineside signalling systems
 - f) RIS-0734-CCS sets out the requirements for the signing of permissible speed limits
 - g) RIS-0737-CCS sets out the requirements for signal sighting assessment
 - h) RIS-0744-CCS sets out requirements for permissive working risk assessment
 - i) RIS-0758-CCS sets out the requirements for lineside signal aspects and indications so that they can be interpreted.

1.4 Health and safety responsibilities

- 1.4.1 Users of documents published by RSSB are reminded of the need to consider their own responsibilities to ensure health and safety at work and their own duties under health and safety legislation. RSSB does not warrant that compliance with all or any documents published by RSSB is sufficient in itself to ensure safe systems of work or operation or to satisfy such responsibilities or duties.

1.5 Structure of this document

- 1.5.1 This document sets out a series of requirements that are sequentially numbered. This document also sets out the rationale for the requirement, explaining why the requirement is needed and its purpose and, where relevant, guidance to support the requirement. The rationale and the guidance are prefixed by the letter 'G'.
- 1.5.2 Some subjects do not have specific requirements but the subject is addressed through guidance only and, where this is the case, it is distinguished under a heading of 'Guidance' and is prefixed by the letter 'G'.

1.6 Approval and Authorisation

- 1.6.1 The content of this document was approved by Control Command and Signalling Standards Committee (CCS SC) on 29th June 2023.
- 1.6.2 This document was authorised by RSSB on 21st September 2023 .

Part 2 Requirements for Movement Authorities

2.1 Providing signalled MAs

2.1.1 Provision of lineside signals

2.1.1.1 On lines where trains are operated using a lineside signalling system, lineside signals shall be provided to authorise the train movements specified in the operating specification.

Rationale

G 2.1.1.2 Signal aspects are the means of issuing a movement authority (MA) to trains that operate on lines fitted with a lineside signalling system, and when a cab signalling system is not in use.

G 2.1.1.3 Train drivers read and interpret the signal aspects to understand the MA. Driveability is supported if all necessary MA information is provided by the signalling system.

G 2.1.1.4 Conformity with this requirement can be used to control the following driveability hazard precursor listed in section 1.3.2:

Necessary MA information is not provided by the signalling system

Guidance

G 2.1.1.5 The operating specification describes the train movements that require a signalled MA. It is produced by the infrastructure manager in collaboration with the railway undertakings who will use the route.

G 2.1.1.6 Signalled MAs can be provided using colour light signals or semaphore signals, or a combination of both. RIS-0758-CCS sets out requirements for lineside signal aspects and the information they convey.

G 2.1.1.7 The type and layout of signals is influenced by the operational context on the route and the method of block signalling applied. The requirements in this document are consistent with the following methods of block signalling used on the GB mainline railway:

- a) Track circuit block (TCB)
- b) Absolute block (AB)
- c) Tokenless block (TB)
- d) Electric token block (ETB)
- e) No-signaller token block (NST)
- f) No-signaller token block-remote (NSTR)
- g) One-train system with staff
- h) One-train system without staff
- i) Radio electronic token block (RETB).

Signalling Layout and Signal Aspect Sequence Requirements

- G 2.1.1.8 In some cases a transition from one method of block signalling to another means that drivers experience a change to the layout of signals and sequence of signal aspects; for example, at a transition from TCB to AB, the consistency of signal spacing changes from 3- or 4-aspect signalling to a layout incorporating distant signals and closely spaced home signals, with approach controls to regulate train movements within station limits. Driveability assessment is used to confirm that transitions between different block systems are driveable.
- G 2.1.1.9 Some of these systems incorporate transfer of a token or one-train staff as part of the MA process. GKRT0055 provides further requirements and guidance on block systems and provision of lineside signals.
- G 2.1.1.10 The lineside signalling system is capable of being configured to convey the following types of MA to train drivers:
- Full MA, which authorises a train movement into an unoccupied signal section. The end of MA is denoted by a main stop aspect
 - On-sight MA, which authorises a train movement into a signal section that is already occupied by another train or rail vehicle. The train driver is responsible for stopping the train clear of any obstruction
 - Shunt MA, which authorises a shunting movement into a signal section, or along any line that may be occupied or clear. The train driver is responsible for stopping the train clear of any obstruction
 - Proceed on sight authority (PoSA) MA, which authorises a train movement into a signal section when the signalling system has failed and is unable to provide the required MA. The train driver is responsible for stopping the train clear of any obstruction.
- G 2.1.1.11 The relationship between the type of MAs, the classes of route and the type of signal aspect is shown in Table 1.

Type of MA	Class of signal route	Type of signal aspect #1	Remarks
Full	Main	Main proceed	
	Warning #2	Main proceed - approach controlled	Single yellow
On-sight	Calling-on	Permissive	Position light with a main stop aspect
Shunt	Shunt	Shunt	Position light
PoSA	PoSA	PoSA	Flashing position light
<p>#1 RIS-0758-CCS sets out requirements for lineside signal aspects and the information they convey.</p> <p>#2 The warning class route is a signal overrun risk mitigation measure that influences the design of the controls to provide a full MA when the full overlap is unavailable.</p>			

Table 1: Types of MA, signal route classes and signal aspects

- G 2.1.1.12 On lines fitted with both a lineside signalling system and a cab signalling system, the types of MAs and coverage of each signalling system can be different.
- G 2.1.1.13 The type of signal provided and the signal aspects that can be shown by a signal are influenced by:
- The classes of signal route provided in the interlocking
 - The types and classes of trains that will be operated
 - The types of train movement that will take place; for example, shunting, coupling two trains
 - Train speeds
 - The method of signalling applicable on the line, and
 - The output from the signal sighting assessment.

2.1.2 Cancelling and reissuing a signalled movement authority

- 2.1.2.1 After a stop signal has been cleared to show a proceed aspect, that signal shall not provide a movement authority (MA) towards a different line, or a different type of MA on the same line, until it has been controlled to show the stop aspect and one of the following conditions applies:
- After the stop aspect is shown, any approaching train has had enough time to stop, or
 - When the signal is controlled to show the stop aspect, no approaching train has passed the required readable distance (RRD) of a signal that forms part of a standard cautionary aspect sequence, and which would revert to a more restrictive signal aspect, or an indicator that would revert to a more restrictive route indication.

Rationale

- G 2.1.2.2 The signalling system is designed so that signals can be safely controlled to their most restrictive signal aspect at any time. Requirement [2.1.2.1](#) is intended to reduce the likelihood of an operating incident (such as a train-on-train collision or a derailment) by preventing a signal from being replaced to danger and cleared again for a movement towards a different line or a different type of MA until it is safe to do so.
- G 2.1.2.3 The stop aspect is relevant to stopping the train when the MA is withdrawn.
- G 2.1.2.4 The stop aspect is shown until the train driver can reliably control the train to conform with the procedures applicable to a different MA.
- G 2.1.2.5 Conformity with this requirement can be used to control the following driveability hazard precursor listed in section [1.3.2](#):

Insufficient time for the train driver to comply with the operating requirement

Guidance

- G 2.1.2.6 The interlocking functionality provided to comply with this requirement is known as approach locking. Approach locking maintains the integrity of the signal route for a sufficient time to allow a train using the cancelled MA to either stop at the signal denoting the new limit of MA or pass that signal and lock the signal route ahead. It is typically used to prevent the setting of conflicting signal routes, the operation of associated moveable infrastructure and the opening of level crossings until it is safe to do so.
- G 2.1.2.7 With reference to [2.1.2.1 b\)](#), approach locking is not applicable to a signal that reverts to a more restrictive aspect for a purpose other than conformity with requirements [2.7.2](#) and [2.7.3.1](#). Examples of a more restrictive route indication include:
- a) A banner repeater that changes from a green OFF indication to a white indication
 - b) A preliminary route indicator that changes from lit to unlit
 - c) A banner junction indicator that extinguishes the arrow indication.
- G 2.1.2.8 Three applications of approach locking are available:
- a) Approach locked when cleared. This is the simplest form of approach locking, which is sufficient to achieve conformity with [2.1.2.1 a\)](#)
 - b) Comprehensive approach locking. This applies the approach locking only when a train is detected to be approaching the outermost signal that would change to show a different aspect when the original MA is cancelled. This arrangement is relevant to conformity with [b\)](#)
 - c) Selective comprehensive approach locking: This applies comprehensive approach locking to the signal only when approached from some lines; other signalled approaches being approach locked when cleared.
- G 2.1.2.9 Comprehensive approach locking results in a more complex interlocking design and is provided only if there is an overall performance benefit, for example, through operating efficiencies.
- G 2.1.2.10 It is not necessary to provide additional train detection locations to specifically apply the comprehensive approach locking at the RRD to conform with this requirement.
- G 2.1.2.11 The location at which comprehensive approach locking is applied takes account of any transmission delays that could delay the replacement of signal aspects.
- G 2.1.2.12 Historical design practice for comprehensive approach locking on the GB mainline railway is to apply the approach locking when the train reaches the first train detection location after passing the last signal that would not change aspect and before it reaches the RRD of the signal that would change aspect.
- G 2.1.2.13 The approach locking is released after sufficient time has elapsed for either:
- a) The train driver to stop the train at the signal showing the stop aspect, or
 - b) The train to overrun the signal and cause the train detection system to activate the route locking beyond that signal.
- G 2.1.2.14 The approach locking release time for each stop signal takes account of signal spacing, the possible variation in position of the train between consecutive signals when the MA is cancelled.

2.1.3 Proving of signal aspects and indications

Guidance on signal aspect or indication failures

- G 2.1.3.1 Conformity with the requirements for providing signalled movement authorities (MAs) to trains is dependent on the capability of the lineside signalling system to reliably show correct and complete sequences of signal aspects and indications. Two failure scenarios adversely impact on this capability in the operational context:
- An extinguished signal or indicator
 - A degraded or corrupted signal aspect or indication.
- G 2.1.3.2 Both failure scenarios could increase the risk of an operating incident; for example:
- An extinguished signal that should be showing a stop aspect or cautionary aspect could increase signal passed at danger (SPAD) risk
 - An extinguished, degraded or corrupted indication of route could increase the risk of a train exceeding the permissible speed on a diverging line with a lower permissible speed limit
 - An extinguished signal or indicator might remove a visible cue to a train driver about where to apply the brake to stop at a station, or comply with a reduction in permissible speed.
- G 2.1.3.3 The risk of an extinguished or corrupted signal aspect or indication is typically influenced by infrastructure characteristics, the positions of other trains and environmental conditions.
- G 2.1.3.4 Potential causes of a failure include:
- Loss of power supply; for example, a blown fuse
 - Signal equipment fault; for example, a faulty light unit or a mechanical signal fitting that is out of adjustment
 - Electrical circuit fault; for example, a damaged or disconnected cable.
- G 2.1.3.5 Availability can be improved by incorporating redundancy into the signalling system, in combination with an appropriate failure indication and repair response capability. Examples of redundancy include:
- Generating each display using multiple lit elements; for example, an array of light emitting diodes (LEDs)
 - Providing standby capability in combination with a change-over control; for example, a secondary power supply or dual filament lamp.
- G 2.1.3.6 The frequency of failures can be reduced by implementing equipment that supports a high level of reliability together with an asset management system that maintains the equipment within acceptable tolerances. This includes routinely replacing consumable components before they fail and implementing measures to protect assets from physical damage; for example, by protecting cross-track tail cables for the duration of track maintenance work.
- G 2.1.3.7 The consequence of a failure depends on the impact on the train driving task, which is informed by the signal aspects and indications shown on the approach, as well as route knowledge and previous experience of train driving on the route. Failure

consequence can be described in terms of the driveability hazard precursors that arise; for example:

- a) Necessary MA information is not provided by the signalling system
- b) Information provided by the signalling system is not complete
- c) Information provided by the signalling system cannot be relied upon
- d) Poor accuracy of the information provided by the signalling system
- e) Inconsistent signal aspects and indications presented along the route
- f) Insufficient time for the train driver to comply with the operating requirement.

G 2.1.3.8 Further guidance on the driveability hazard precursors is provided in RIS-0713-CCS.

Guidance on failure detection

G 2.1.3.9 Although the physical characteristics of signals and indicators include some features that support visibility and readability performance, in most cases the biggest contributors are the lit elements. The visibility of an extinguished signal or indicator may be very poor, particularly in a dark environment. Further guidance on the features of lineside signalling equipment that support visibility and readability is provided in GKRT0057.

G 2.1.3.10 Poor visibility of extinguished signals and indicators, and poor readability or interpretability of degraded and corrupted signal aspects and indications means that train drivers cannot reliably detect failures.

G 2.1.3.11 A failure that extinguishes a signal aspect or indication means that some of the information usually provided by the signalling system cannot be obtained by train drivers. A failure that causes a corrupted display might change the meaning of what is shown; for example, an alphanumeric character that degrades to the appearance of a different valid character. RIS-0758-CCS sets out the requirements for the appearance and meanings of signal aspects and indications.

G 2.1.3.12 Where a signal protects a signal section on a running line, or a hazard in a siding, the signalling system can be configured to detect that the signal aspects and indications are properly shown before a MA is provided to a train:

- a) The capability to detect that lit signal aspects and indications are properly shown is known as 'lamp proving'
- b) The capability to detect that mechanical signal arms and indicators are shown in the correct position is known as 'arm proving'.

G 2.1.3.13 The method used to implement lamp proving capability is dependent on the technology used to generate the displays; the following methods are available:

- a) Detecting that the lighting circuit is intact, or
- b) Detecting that sufficient light is being generated.

G 2.1.3.14 Arm proving capability is typically implemented using an electro-mechanical device connected to the signal arm, with electrical contacts that complete an electrical circuit when the alignment of the signal arm conforms with required tolerances.

G 2.1.3.15 If the detection output is not detected, it is assumed that the signal aspect or indication is in a failed state. The outputs from lamp proving and arm proving can be implemented as controls within the signalling system or as failure indications.

- G 2.1.3.16 The application of proving controls or failure indications is proportionate to the risk arising from a failure and the impact on performance. Proving controls can be omitted if the risk of a failure is inconsequential or mitigated by other means, for example:
- Where the lit elements are supplementary to a retro-reflective feature; for example, a buffer beam
 - Where failure of one lit element results in a more restrictive display; for example, one element of a double yellow cautionary aspect.

Guidance on the application of lamp proving controls

- G 2.1.3.17 There are two types of lamp proving control:
- 'Lamp alight control', which prevents an MA from being provided towards a signal that is extinguished, or which is showing a degraded or corrupted aspect or indication
 - 'Lamp alight-or-OFF control', which prevents an MA from being provided towards a signal that is extinguished, or which is showing a degraded or corrupted aspect or indication, unless that signal is controlled to a proceed aspect.
- G 2.1.3.18 The existing type of lamp proving control implemented within a geographical area is largely dependent on the design policy when the line was last resignalled. When a lineside signalling system is being modified or replaced on an operational equivalent basis, the existing type of lamp proving control is available as a reference system, and could be perpetuated if the assumptions and dependencies underpinning the original risk assessment remain valid; for example, system reliability, the number and frequency of trains.
- G 2.1.3.19 Where lamp proving at a junction signal is used, lamp proving controls can be configured so that a proceed aspect is shown by that signal only if:
- The associated route indication is lit, and
 - The route indication is sufficiently complete to be interpretable.
- G 2.1.3.20 Lamp proving controls at a preliminary route indicator (PRI) can be configured so that a failure to show the arrow indication causes the previous signal to revert to the cautionary aspect usually shown when the junction signal is showing the stop aspect. Deceleration of the train in response to the cautionary aspect means that mis-routing risk is mitigated by interpretability of the junction signal proceed aspect and route indication.
- G 2.1.3.21 Lamp proving controls can be provided to control any overspeed risk arising from a failure of a junction cautionary aspect that could result in a driver misinterpreting which route is set at the junction. Lamp proving controls can be omitted if a failure would result in a signal aspect that is consistent with the MAR sequence; for example, a failure that results in a single yellow aspect instead of a flashing single yellow aspect.
- G 2.1.3.22 Where the required readable distance (RRD) of a signal includes a banner repeater indicator, the lamp proving controls applicable to the signal aspects and route indications can be extended to include the associated repeater indications.

- G 2.1.3.23 Where a splitting banner repeater indicator is provided, lamp proving controls can be used to prove that a banner-ON indication is always presented by one indicator head. A splitting banner-OFF indication proves that the indicator head showing the banner-ON indication is lit.
- G 2.1.3.24 Banner junction indicators incorporate controls so that a banner-OFF indication proves that the arrow indication is lit.

2.2 Requirements for stop signals

2.2.1 Locations where stop signals are required

- 2.2.1.1 A stop signal shall be provided at every infrastructure location where a limit of movement authority (limit of MA) protects a signal section on a running line.

Rationale

- G 2.2.1.2 When a train is stationary, the train driver reads and interprets the applicable stop aspect to understand that no signalled MA is available to start a train movement.
- G 2.2.1.3 When a train is moving, the train driver reads and interprets the applicable stop aspect to understand the location of the end of MA.
- G 2.2.1.4 Driveability is supported if the signalling system provides all of the MA information needed by drivers. The stop aspect provides all of the information needed by the train driver to understand the limit of MA without reference to anything else.
- G 2.2.1.5 Conformity with this requirement can be used to control the following driveability hazard precursor listed in section 1.3.2:

Necessary MA information is not provided by the signalling system

Guidance on positioning stop signals

- G 2.2.1.6 This requirement applies to all stop signals, including those provided at an infrastructure location where there is no preceding MA.
- G 2.2.1.7 Stop signals indicate the limits of each signal section and block section on running lines and the limits of signalled MAs in sidings. Running lines are identified in Table A of the Sectional Appendix and signalling record plans maintained by the infrastructure manager (IM).
- G 2.2.1.8 Stop signals are used to maintain separation between trains and to control MAs at locations where the signal section is not yet available, including junctions, level crossings, station platforms, tunnels, viaducts or where there is a hazard caused by a third party (for example, low flying aircraft).
- G 2.2.1.9 Stop signals are also part of a train dispatch system. Station operators use the stop aspect to understand that the train is not to be dispatched.
- G 2.2.1.10 The actual train stopping position on the approach to a stop signal is usually specified in the train driving policy implemented by each railway undertaking (RU). A different

stopping position may be specified by different RUs. At some locations, car stop markers remind train drivers of the stopping positions for particular train formations and operations. Where these are provided, the stop aspect continues to denote the limit of MA. RIS-3782-TOM sets out requirements for the application of car stop markers.

G 2.2.1.11 Stop signals are only provided to indicate the limit of a signalled MA. Other locations where trains stop and start (for example, intermediate station stops and starts), are managed using drivers' route knowledge and operational rules.

G 2.2.1.12 A stop signal can issue an MA that is valid for an out-and-back train movement, for example for a movement to the end of a single line and back subject to operational risk being controlled (for example, level crossing risk). Provision of a stop signal for the reversing movement would provide the capability to:

- a) Mitigate level crossing collision risk
- b) Operate a one-train-working single line system
- c) Regulate train movements.

G 2.2.1.13 If an MA is for a train movement towards a siding, the MA is provided by a shunt signal so that the train driver interprets the requirement to stop the train clear of any obstruction. It is only necessary to provide a stop signal to indicate the limit of MA if this is located at the transition to the siding. Where the MA is towards a depot or yard, it is good practice for the infrastructure manager (IM) to document the agreed train working arrangements with the facility operator.

G 2.2.1.14 A buffer stop on a siding is not a limit of signalled MA and is not presented as a stop signal.

G 2.2.1.15 Where a stop signal denotes the end of MA for trains that reverse, the following factors are relevant to determining the optimum position:

- a) The readability of the signal that will provide the MA for the reversing move
- b) The location of any moveable infrastructure and level crossings relative to the train after it has stopped
- c) The location of any train protection system or automatic warning system (AWS) track equipment.

G 2.2.1.16 The following factors are examples of other things that can influence the optimum position of stop signals:

- a) Required headways
- b) Safe integration of train operations with track systems and structures. The position of stop signals influences the position of the rear of the train after it has stopped, which can affect infrastructure capacity at junctions or safe operation at stations. Risk assessment is used to evaluate the risk of positioning a stop signal so that part of train would stop within a tunnel, on a viaduct or over catch points
- c) Safe integration with railway operating functions. For example, the optimum position of a stop signal can be influenced by the need for the train driver to use trackside equipment (for example, a token instrument) or communicate directly with a local operator before the train passes the signal

- d) Safe integration with level crossings and level crossing systems; for example, so that the rear of a stationary train does not obstruct a level crossing that would be otherwise open to the highway after the train has passed. RIS-0792-CCS sets out further guidance on the positioning of stop signals relative to level crossings
- e) Technical compatibility of the train with other subsystems on the route, for example, the electrification system.

Guidance on technical compatibility with electric traction systems

- G 2.2.1.17 The route technical compatibility assessment process is used to confirm that the relative position of stop signals and electric traction system features supports technical compatibility with the trains operated on the route. RIS-8270-RST sets out the requirements for applying the route technical compatibility assessment process.
- G 2.2.1.18 The position of stop signals on an electrified line has an influence on the following:
 - a) Technical compatibility at interfaces between the energy (ENE) subsystem and electrically powered rail vehicles. Incompatibility at these interfaces is a hazard that can arise when operating electric trains on the route
 - b) Readability. Signal sighting can be obscured by overhead contact line (OCL) equipment. RIS-0737-CCS sets out the requirements for signal sighting assessment, which includes the assessment of obscuration
 - c) Driveability. The operation of electric trains or multi-mode trains can influence driveability if it increases train driver workload. In particular, this is the case if the train driver is required to respond to lineside operational signs as well as signal aspects and indications, or is presented with conflicting information or the required response results in multiple tasks at the same time.
- G 2.2.1.19 RIS-2713-RST sets out the requirements for the introduction and operation of multi-mode rolling stock, including the application of lineside operational signs with traction changeover locations.
- G 2.2.1.20 GLRT1210 and GLRT1212 set out the requirements on the ENE subsystems and interfaces to the rolling stock subsystem. Meeting these requirements, including the application of lineside operational signs with traction changeover locations and phase separation sections, is intended to assist in controlling the likelihood of:
 - a) Isolation of the train from the infrastructure power source
 - b) Damage to ENE subsystem components
 - c) Bridging in-line insulation.
- G 2.2.1.21 The position of stop signals influences the stopping position of trains on the route and therefore the likelihood of isolation of the train, damage to ENE subsystem components or bridging in-line insulation, if the pantograph or collector shoe stops close to any of the following:
 - a) In ac electrified areas: a neutral section, pantograph exclusion zone, section insulator or overlap
 - b) In dc electrified areas: conductor rail gaps
 - c) Automatic power control system infrastructure.

Guidance on parallel positioning of signals

- G 2.2.1.22 Where parallel lines on a multi-track route are signalled in the same direction, locating signals so that they are in a similar longitudinal position can support driveability by making it easier for train drivers to:
- Identify which signal is applicable
 - Judge the required stopping position of the train when the limit of MA is at that signal
 - Develop and retain route knowledge.
- G 2.2.1.23 In the signalling design context, this is known as 'parallel positioning of signals'.
- G 2.2.1.24 Parallel position of signals is achieved when the relevant signals are mounted on the same structure or where separate signal structures are located in a similar longitudinal position (typically +/-20 m). The tolerance allows for:
- Site specific positioning constraints
 - Flexibility in achieving a design that optimises readability
 - Compatibility with train detection systems.
- G 2.2.1.25 The position of signals is influenced by the physical environment, the operational context and the signal sighting assessment. A signal sighting assessment might conclude that parallel positioning of signals does not provide an overall operational benefit. Where parallel positioning of signals is not practicable, other factors are assessed to confirm that the layout is driveable, for example:
- Where the signals control the exit from a terminal station and the primary objective is for the driver to observe the signal before the train can start
 - Where there is a distinctive separation between parallel lines, for example a station platform, structure or wide spacing
 - Where the signals on different lines have a distinctive appearance (for example, where the parallel line utilises a metro-style signalling system)
 - Where the signals on different lines have a distinctive configuration (for example, relative height or position relative to the line).
- G 2.2.1.26 Where parallel positioning of signals cannot be achieved, signal sighting assessment is used to assess the impact of locating signals that are not parallel. RIS-0737-CCS sets out the signal sighting assessment process, which includes assessment of the impact of:
- Multiple lineside signalling assets of similar appearance in the drivers field of vision
 - Non-preferred asset or display position relative to the line
 - Other lineside signalling asset more conspicuous than the target lineside signalling asset
 - Inconsistent appearance
 - Poor visual association with related infrastructure.

Guidance on using stop signals to protect other railway operations

- G 2.2.1.27 A stop signal is used to control train movements between parts of the railway infrastructure that are being controlled by different operators. For example:

- a) A stop signal is used by the signaller to protect train operations at a ground frame when the ground frame is released to the train operator. In this case the train operator is responsible for authorising train movements using the infrastructure covered by ground frame operations
- b) A release can be applied to a stop signal as part of a system that maintains cooperation between the signaller and another infrastructure manager before issuing an MA for a train movement into a yard or depot
- c) A stop signal is used to protect personnel working on or about the line, using a signalling lockout system
- d) A stop signal is used to protect a level crossing that is operated by train crew. The stop aspect (typically a stop board) identifies a location where the train is required to stop before the level crossing is operated.

2.2.2 Application of independent shunting signals

2.2.2.1 A limit of movement authority (limit of MA) shall be indicated using an independent shunting signal only if one of the following applies:

- a) No signalled train movements can approach the signal, or
- b) All signalled train movements that can approach the signal are using a shunt MA.

Rationale

G 2.2.2.2 Independent shunting signals support a readable distance performance that provides the minimum reading time (MRT) only sufficient for slow train speeds, such as those associated with shunting operations.

G 2.2.2.3 Train drivers expect to read a main stop aspect when using anything other than a shunt MA.

G 2.2.2.4 This requirement can be applied to control the following driveability hazard precursors as described in section [1.3.2](#):

Poor readability Inconsistent signal aspects and indications presented along the line
--

Guidance

G 2.2.2.5 The end of a shunt MA can be indicated by a main stop signal or an independent shunting signal. The end of a full MA is always indicated by a main stop signal.

G 2.2.2.6 The operating specification might mean that an independent shunting signal is located between two main stop signals facing the direction of travel. In this case, any main signal routes towards the shunting signal 'preset' the shunt aspect and have a limit of MA beyond it.

G 2.2.2.7 It is good practice to protect running lines at the exit from a yard or depot using a main stop signal. The main proceed aspect enables the train driver to interpret the aspect shown by the next signal ahead. Provision of an independent shunting signal is informed by a driveability assessment. Signal overrun risk assessment is used to

confirm that the level of signal overrun risk at the exit signal and at the end of MA is acceptable.

2.2.3 Preset stop signals and preceding stop signals

Guidance

- G 2.2.3.1 A stop signal can be preset or preceded by another stop signal, and it is possible for both controls to be applied to the same stop signal. The application of presetting or preceding controls is informed by the signalling layout and the operating specification.
- G 2.2.3.2 A presetting control is usually provided to meet an operating requirement. Examples of a presetting control include:
- A 'non-approachable red aspect' control, which is typically used to support the readability of another signal
 - A 'conditional double red aspect' (CDR) control, which is typically used to improve the effectiveness of the train protection and warning system (TPWS)
 - A 'preset shunt aspect' control, which is typically applied to a shunt signal provided on a running line in the facing direction. The shunt aspect does not need to be read by the train driver but is consistent with the full movement authority (full MA) being used by the train.
- G 2.2.3.3 Figure 1 shows an example of a preset shunt signal. In this case, position light signal 701 is preset by colour light signal 101 so that the driver will not see a stop aspect when the full MA is available from signal 101 towards 103. Position light signal 701 can also work independently to provide a shunt MA from the down main into the siding or towards signal 103.

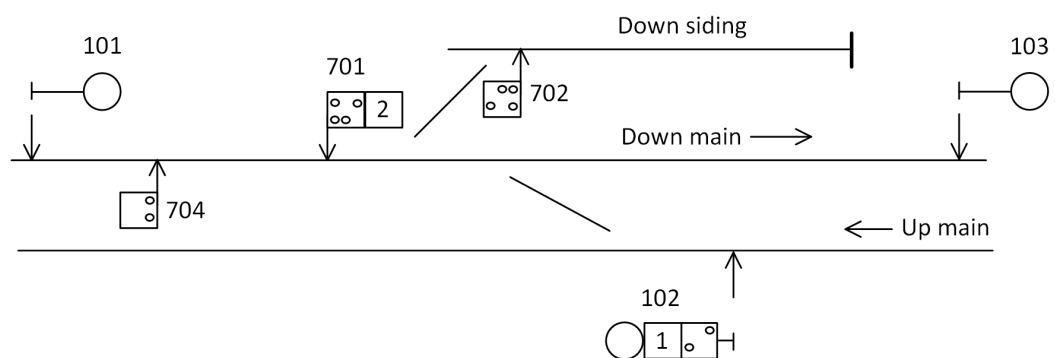

Figure 1: Example of a preset shunt signal

- G 2.2.3.4 Preceding signals are controlled to a proceed aspect before the signals that they precede. They show signal aspects that need to be read by the train driver but they do not denote the limit of MA. Figure 2 shows an example where position light signal 1204 precedes 1206 for a set back move over 701 crossover behind signal 1201. In this case, making 1204 a preceding signal avoids the need to consider overlap controls and manage overrun risk at this signal.

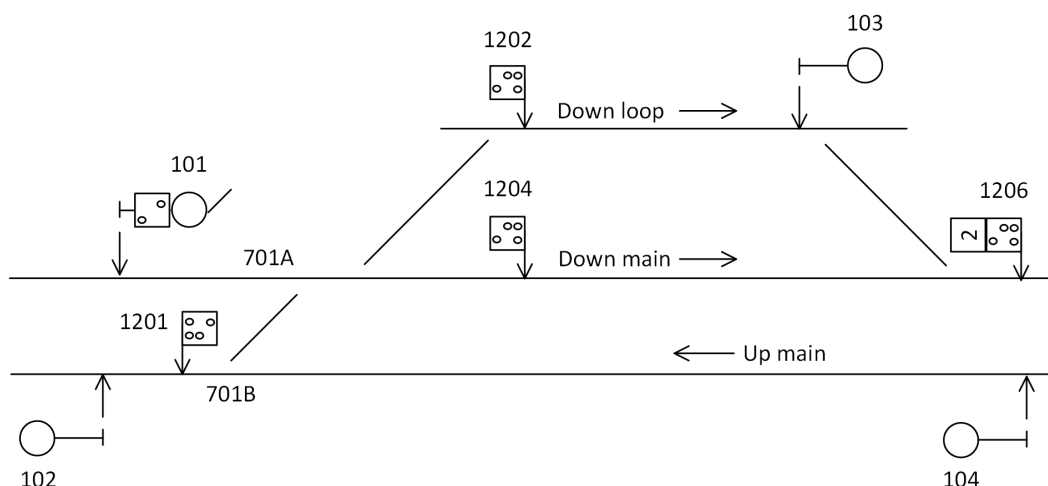

Figure 2: Example of a preceding shunt signal

2.3 Requirements for indicating the limit of MA (stop aspects)

2.3.1 Showing the stop aspect

2.3.1.1 A stop signal shall show a stop aspect when a movement authority (MA) is not available beyond that signal, except when the conditions for extinguishing an approach-lit signal are met.

Rationale

G 2.3.1.2 The stop aspect indicates the limit of MA to the train driver. If it is not readable, the train might exceed the limit of MA.

G 2.3.1.3 Conformity with this requirement can be used to control the following driveability hazard precursors listed in section 1.3.2:

Necessary MA information is not provided by the signalling system
 Poor readability

Guidance

G 2.3.1.4 RIS-0758-CCS sets out further requirements for approach lit signal aspects.

2.3.2 Consistency of stop aspect appearance

2.3.2.1 Each stop signal shall be capable of showing only one type of stop aspect.

Rationale

G 2.3.2.2 All stop aspects codify the same information and require the train driver to apply the same rules, so there is no need to show different stop aspects at the same signal.

G 2.3.2.3 The consistent appearance of each stop aspect and its arrangement within the train driver's field of vision supports the development and retention of train drivers' route knowledge, which includes the arrangement of stop aspects within the signalling layout and releases capacity for the train driver to deal with the demands of other systems.

G 2.3.2.4 Conformity with this requirement can be used to control the following driveability hazard precursor listed in section 1.3.2:

Inconsistent signal aspects and indications presented along the line

Guidance

G 2.3.2.5 RIS-0758-CCS sets out the requirements for the appearance and meaning of stop aspects.

2.3.3 Indicating the end of a signalled line

2.3.3.1 The buffer stop at the end of a signalled line shall have the appearance of a stop aspect.

Rationale

G 2.3.3.2 The distinctive and consistent appearance of the limit of movement authority at a buffer stop can reduce the likelihood of a buffer stop collision.

G 2.3.3.3 Conformity with this requirement can be used to control the following driveability hazard precursors listed in section 1.3.2:

Information provided by the signalling system is not complete
Poor interpretability

Guidance

G 2.3.3.4 RIS-0737-CCS and RIS-0758-CCS set out the requirements for the appearance of a buffer stop that denotes a stop aspect; a retro-reflective buffer beam, which may be supplemented by red lights or white lights.

2.4 Requirements for shunt MAs (shunt aspects)

2.4.1 Shunt aspect shown by an independent shunting signal

2.4.1.1 An independent shunting signal shall show the shunt aspect when a shunt movement authority (shunt MA) is provided by that signal, or when it is preset.

Rationale

G 2.4.1.2 The shunt aspect provides the shunt MA to the train.

- G 2.4.1.3 When an independent shunting signal is controlled as a preset shunt, the proceed aspect is consistent with the MA provided to the train at the previous signal.
- G 2.4.1.4 Conformity with this requirement can be used to control the following driveability hazard precursors listed in section [1.3.2](#):

Necessary MA information is not provided by the signalling system

Poor accuracy of the provided information

Guidance

- G 2.4.1.5 A shunt MA authorises a train driver to proceed at caution towards the next train, signal or buffer stop, and be prepared to stop short of any obstruction.
- G 2.4.1.6 RIS-0758-CCS sets out the appearance requirements for shunt aspects. A shunt MA is provided by a shunt aspect, which can be shown using a position light signal or semaphore shunting signal equipment.
- G 2.4.1.7 A position light OFF aspect is also used to provide an on-sight MA for train movements into an occupied signal section; however, different interlocking controls and signalling rules apply to these. Further requirements for showing a position light OFF aspect at a main stop signal are set out in [2.5.1](#).
- G 2.4.1.8 A shunt MA is interlocked using a shunt class of signal route. The interlocking can omit some or all train detection controls, or prove the signal section is clear, before the shunt MA is provided, however the shunt aspect does not enable the driver to distinguish whether the line is occupied or clear. Nor does it provide any information about the aspect shown by the next signal. This can increase the likelihood of:
 - a) A train-on-train collision if previous experience results in a train driver anticipating the signal section is clear when it is occupied, or
 - b) A signal overrun at the next signal ahead if previous experience results in a train driver anticipating a proceed aspect at the next signal.
- G 2.4.1.9 A preset shunt signal is controlled to show a proceed aspect when a signal route is set for a train movement to pass that location.
- G 2.4.1.10 RIS-0713-CCS sets out further requirement for assessing the driveability an independent shunting signal on a running line.

2.4.2 Position of independent shunting signals

- 2.4.2.1 The independent shunting signal shall be positioned at the infrastructure location beyond which the shunt movement authority (shunt MA) applies.

Rationale

- G 2.4.2.2 Train drivers understand that the position of a shunt aspect is always at the start of the shunt MA, unless it is preset by a main aspect. The shunt aspect provides all of the information needed by the train driver to understand that a shunt MA is available without reference to anything else.

- G 2.4.2.3 Conformity with this requirement can be used to control the following driveability hazard precursor listed in section 1.3.2:

Inconsistent infrastructure location of one or more signalling assets

Guidance

- G 2.4.2.4 An independent shunting signal is a type of stop signal; therefore the positioning requirements relevant to stop signals and stop aspects also apply.

2.4.3 Aspects shown by independent shunting signals being controlled as preset shunts

- 2.4.3.1 An independent shunting signal shall show the shunt aspect when it is being controlled as a preset shunt signal.

- 2.4.3.2 An independent shunting signal that is being controlled as a preset shunt shall show the stop aspect when the movement authority (MA) towards that signal is cancelled before the train passes the main stop signal on the approach.

Rationale

- G 2.4.3.3 When the signal is preset, the shunt aspect is shown so that the train driver will not observe a stop aspect that falsely implies a limit of MA between two main signals, or an extinguished signal aspect, which might be interpreted as a system failure.

- G 2.4.3.4 The stop aspect reflects the actual status of the MA. It is shown so that the train driver will not observe a proceed aspect that falsely implies that MA is available. The signal also provides another opportunity for the driver to read a stop aspect after the train has exceeded a limit of MA in the event that the driver does not have enough time to read and respond to the main stop aspect.

- G 2.4.3.5 Conformity with these requirements can be used to control the following driveability hazard precursor listed in section 1.3.2:

Provided information is not relevant to some trains

Guidance

- G 2.4.3.6 Although a preset shunt aspect might not be readable at the permissible speed, in this context it does not have to be readable because the driver is not expected to use the information it conveys.

2.5 Requirement for on-sight MAs and shunt MAs

2.5.1 Position light OFF aspect shown at a main stop signal

- 2.5.1.1 A colour light signal shall show a position light OFF aspect in combination with a main stop aspect when an on-sight movement authority (on-sight MA) or a shunt MA is available at that location.

2.5.1.2 Where a colour light signal shows an alphanumeric route indication with a position light OFF aspect, the OFF aspect shall be shown only when the train has reached a location where the route indication can be interpreted by the train driver.

Rationale

G 2.5.1.3 The position light OFF aspect provides the MA to the train. The alphanumeric route indication enables the driver to interpret which route the MA applies to, and in some cases distinguish an on-sight MA that can be used by a passenger train from a shunt MA.

G 2.5.1.4 Conformity with these requirements can be used to control the following driveability hazard precursors listed in section 1.3.2:

Necessary MA information is not provided by the signalling system
Poor accuracy of the provided information

Guidance

G 2.5.1.5 The position light OFF aspect for an on-sight MA or a shunt MA has the same appearance, however the signalling system controls are different and the MAs are intended to be used for different operations.

G 2.5.1.6 A shunt MA is interlocked using a shunt class of signal route. An on-sight MA is interlocked using a calling-on class of signal route.

G 2.5.1.7 The train detection controls provided to control passenger train collision risk during a permissive movement might be too restrictive for a shunting movement. Train detection controls for shunt MAs are limited to those track sections that are necessary to control collision risk when shunting.

G 2.5.1.8 Because the position light OFF aspect does not provide any visible characteristics to help train drivers distinguish between an on-sight MA and shunt MA, it is good practice to avoid providing both at a signal for train movements along the same line. Where the operating specification means that both types of MA are needed along the same line, a permissive working risk assessment is used to confirm that risk is acceptable. Examples of operating incidents include:

- a) A passenger train uses a shunt MA when it is not authorised to do so
- b) A train overruns the limit of MA at an independent shunting signal located within a permissive signal section
- c) A train-on-train collision within a section of line that the train driver expected to be clear.

G 2.5.1.9 The same signal can show a position light OFF aspect for an on-sight MA and a shunt MA along different lines. In this case a route indication helps the train driver to interpret which type of MA is provided and which line it applies to. Further requirements for position light OFF aspects are set out in 3.2.2 and 3.3.

G 2.5.1.10 The readability performance capability of position light signal aspects and route indications means that on-sight MAs are provided only when the train is close to the

signal and preparing stop at it. A proposal to deviate from [2.5.4.1](#) is supported by permissive working risk assessment and signal sighting assessment.

- G 2.5.1.11 The assumed position of the approaching train can be evaluated using a separate detection point or timed occupancy of the signal section.

Guidance on on-sight MAs

- G 2.5.1.12 Permissive working results in the hazard of two trains operating within the same signal section, which increases the likelihood of a train-on-train collision. RIS-0744-CCS sets out further risk assessment requirements relevant to controlling this hazard.
- G 2.5.1.13 An on-sight MA authorises a train driver to proceed at caution towards the next train, signal or buffer stop, and be prepared to stop short of any obstruction.
- G 2.5.1.14 Permissive working involves two or more trains occupying the same signal section at the same time. This means that train separation is not being managed by the infrastructure manager using stop signals, and greater reliance is placed on railway undertakings to control the risk of train-on-train collision.
- G 2.5.1.15 Permissive working can provide cost benefits through operational efficiency, which arise from being able to couple trains, attach / detach vehicles and platform sharing at stations, thereby improving passenger experience.
- G 2.5.1.16 Coupling / attaching / detaching is an operational requirement at certain locations as a means of providing direct train services. With multiple unit trains, only joining trains (coupling) requires an on-sight MA; uncoupling does not. With loco-hauled trains, splitting a train (detaching) also requires an on-sight MA to allow locomotive access to vehicles.
- G 2.5.1.17 Historical safety concerns about permissive working were principally directed at platform sharing (which was seen as an optional method of working); the need for permissive working for coupling was considered to be more acceptable.

Guidance on shunt MAs

- G 2.5.1.18 Further requirements and guidance for shunt MAs are set out in [2.4.1](#).

2.5.2 Banner repeater where the signal shows a position light OFF aspect

- 2.5.2.1 A banner repeater indicator shall show the banner ON indication when the repeated colour light signal is showing a position light OFF aspect.

Rationale

- G 2.5.2.2 The banner ON indication repeats the main stop aspect. The banner OFF indicator repeats the main OFF aspect.
- G 2.5.2.3 A banner OFF indication is not shown with a position light OFF aspect because this could result in a driver misinterpreting that the repeated signal is showing a main proceed aspect.

- G 2.5.2.4 Conformity with this requirement can be used to control the following driveability hazard precursor listed in section 1.3.2:

Poor interpretability

Guidance

- G 2.5.2.5 Where a banner repeater indicator is part of a train dispatch system and there is an operating need to show the banner OFF indication with a position light OFF aspect, a proposal to deviate from this requirement is supported by evidence that sufficient mitigation is in place to control the likelihood that a driver will misinterpret which type of MA is available.
- G 2.5.2.6 RIS-0737-CCS sets out further requirements relevant to the provision of banner repeater indicators.

2.5.3 Relevant stop signal for showing a permissive aspect

- 2.5.3.1 The permissive aspect shall be shown by the stop signal beyond which the on-sight movement authority (on-sight MA) applies.

Rationale

- G 2.5.3.2 Train drivers understand that the position of a permissive aspect is always at a location where a train can obtain an on-sight MA and when the on-sight MA is provided, requirements for permissive working apply beyond the signal.
- G 2.5.3.3 Conformity with this requirement can be used to control the following driveability hazard precursor listed in section 1.3.2:

Inconsistent infrastructure location of one or more signalling assets

Guidance

- G 2.5.3.4 The permissive aspect does not provide information about how far the line is clear. This is the responsibility of the driver to identify.

2.5.4 Clearance of a permissive aspect at a main signal

- 2.5.4.1 The permissive aspect shall be shown only when the train to which it applies is assumed to be within 100 m on the approach to that signal.

Rationale

- G 2.5.4.2 Delaying the permissive aspect until the train has almost stopped reduces the likelihood of driver error in transitioning to the train driving task associated with using an on-sight movement authority.
- G 2.5.4.3 Displaying the permissive aspect too early could result in a train not decelerating sufficiently before starting the permissive movement.

- G 2.5.4.4 Conformity with this requirement can be used to control the following driveability hazard precursors listed in section 1.3.2:

Insufficient time for the train driver to comply with the operating requirement
Excessive time for the train driver to comply with the operating requirement.

Guidance

- G 2.5.4.5 100 m is a maximum value. The relationship between the time of clearance of the permissive aspect and the position of the approaching train is an input to the permissive working risk assessment. RIS-0744-CCS sets out the requirements for permissive working risk assessment.
- G 2.5.4.6 Train position on the approach to the signal can be derived using either a separate train detection point or timed occupancy of a train detection section.
- G 2.5.4.7 Using a separate train detection point has the benefit of positive train positioning that is not dependent on an assumed train speed profile but can result in additional cost.
- G 2.5.4.8 Using timed occupancy can result in a more variable time of clearance relative to the train position, which can reduce signal passed at danger (SPAD) risk due to driver anticipation of a permissive aspect.

2.6 Requirements for degraded MAs (PoSA aspects)

2.6.1 PoSA aspects shown at stop signals

- G 2.6.1.1 A stop signal shall show the proceed on-sight authority (PoSA) aspect when a PoSA movement authority (PoSA MA) is provided as far as the next stop signal or, where there is no signal, the end of signalled infrastructure.

Rationale

- G 2.6.1.2 The PoSA aspect makes the PoSA MA available to the train. The driver uses the PoSA aspect to understand that the signalling system has failed and the train may proceed at caution as far as the line is clear, taking account of the next stop aspect.
- G 2.6.1.3 Conformity with this requirement can be used to control the following driveability hazard precursors listed in section 1.3.2:

Necessary MA information is not provided by the signalling system
Poor accuracy of the provided information
Poor interpretability

Guidance

- G 2.6.1.4 The PoSA aspect is part of a system of providing an MA for a train movement as far as the next stop signal when point detection is available but the normal functionality of the lineside signalling system is affected by a failure. The Rule Book sets out procedures for clearing a signal to a PoSA aspect.
- G 2.6.1.5 A PoSA MA is interlocked using a PoSA class of signal route and shown by a flashing position light OFF aspect.
- G 2.6.1.6 The PoSA aspect is used when a failure prevents the normal functionality of the lineside signalling system.
- G 2.6.1.7 Showing a route indication with a PoSA aspect at a junction signal helps the train driver to interpret which line the MA applies to. At a signal fitted with a route indicator, the relevant route indication is shown with the PoSA aspect, if that indication is capable of being shown.
- G 2.6.1.8 Showing the route indication at the same time as the PoSA aspect can reduce the likelihood that the driver will anticipate a different MA before the signal aspect is shown. It is not necessary to prove that the route indication is shown before the PoSA aspect. Operating rules are applicable if the relevant route indication cannot be shown.
- G 2.6.1.9 It is not necessary to provide a separate route indicator for the specific purpose of indicating a route with a PoSA aspect. When a PoSA aspect is presented in lieu of a main proceed aspect, the relevant junction indication or standard alphanumeric indication is used. When a flashing PoSA aspect is shown in lieu of a position light OFF aspect at a main signal, where provided, the relevant miniature alphanumeric route indication is used.
- G 2.6.1.10 Where a signal is located at a station platform, the MA provided by a PoSA aspect can be used as part of a train dispatch system. Risk assessment informs a decision to show the signal OFF indication and RA indication with a PoSA aspect.

2.6.2 Preset shunt signal aspects with a PoSA MA

- 2.6.2.1 When a proceed on-sight authority (PoSA) aspect is shown in lieu of a main proceed aspect or permissive aspect, any preset shunt signals within the signal section shall show the shunt aspect or the PoSA aspect.

Rationale

- G 2.6.2.2 The train driver would not expect to observe a stop aspect at a signal that is usually preset by the main route.
- G 2.6.2.3 The preset shunt signal presents the PoSA aspect if the failure also prevents the shunt aspect from being shown.
- G 2.6.2.4 Conformity with this requirement can be used to control the following driveability hazard precursor listed in section [1.3.2](#):

Insufficient time for the train driver to comply with the operating requirement

Guidance

- G 2.6.2.5 Train drivers are not expected to read the proceed aspect shown by a shunt signal when it is preset, therefore showing the shunt aspect is consistent with operation of a train using a PoSA movement authority (PoSA MA). The capability to show a PoSA MA when a shunting signal is preset is justified if there is a business benefit.

2.7 Requirements for main proceed aspects

2.7.1 Showing a main proceed aspect at stop signals

- 2.7.1.1 A stop signal shall show a main proceed aspect when a full movement authority (full MA) is provided by that signal.

Rationale

- G 2.7.1.2 The main proceed aspect provides the full MA to the train.
- G 2.7.1.3 Conformity with this requirement can be used to control the following driveability hazard precursors listed in section [1.3.2](#):

Necessary MA information is not provided by the signalling system

Poor accuracy of the provided information

Guidance

- G 2.7.1.4 This requirement is applicable to all main stop signals, including non-block signals that are provided to protect a level crossing or a signal section within station limits. Main proceed aspects include unrestricted proceed aspects and cautionary aspects.
- G 2.7.1.5 A full MA is interlocked using a main class or warning class of signal route.
- G 2.7.1.6 Providing a temporary approach control function is a method that assists in controlling over-speed risk when a temporary speed restriction (TSR) is applicable beyond a main stop signal; for example, when the TSR applies to a line, but not all lines, beyond a junction signal. The temporary approach control delays the signal proceed aspect until the train has passed the cautionary aspect presented by the previous signal and can comply with the TSR.

2.7.2 Showing a cautionary aspect sequence

- 2.7.2.1 A full movement authority (full MA) shall incorporate a cautionary aspect sequence on the approach to the main stop aspect denoting the end of the MA, except for full MAs that permit train movements entirely within station limits.

Rationale

- G 2.7.2.2 Outside of station limits, train drivers expect to observe a cautionary aspect sequence when approaching the end of a full MA. The required readable distance (RRD) of the main stop aspect is usually insufficient at the permissible speed to provide enough time for the train driver to respond to, and enough distance for the train to stop at, the limit of MA.
- G 2.7.2.3 At some locations, in non-TCB signalled areas, approach controlled signal aspects are used to authorise train movements within station limits.
- G 2.7.2.4 Conformity with this requirement can be used to control the following driveability hazard precursors listed in section 1.3.2:

Inconsistent signal aspects and indications presented along the line

Insufficient time for the train driver to comply with the operating requirement

Guidance

- G 2.7.2.5 This requirement applies to all types of block system used on the GB mainline railway.
- G 2.7.2.6 The specific requirements for cautionary aspect sequences are set out in 2.8 and 2.9.
- G 2.7.2.7 A signalling layout can include colour light stop signals or semaphore stop signals that do not present a cautionary aspect. For example:
- Where 3-aspect signalling is applied using separate stop (red/green) signals and cautionary (yellow/green or fixed caution) signals
 - In non-TCB areas, stop signals that define signal sections within station limits, including home signals and platform starting signals for train movements towards another home signal or section signal.

2.7.3 Location of first cautionary aspect

- 2.7.3.1 The first cautionary aspect shall be shown at least minimum signalling braking distance (MSBD) from the main stop signal denoting the limit of movement authority (limit of MA).

Rationale

- G 2.7.3.2 MSBD provides enough distance for the train to stop at the limit of MA if the brakes are applied before the train passes the signal showing the first cautionary aspect.
- G 2.7.3.3 Conformity with this requirement can be used to control the following driveability hazard precursor listed in section 1.3.2:

Insufficient time for the train driver to comply with the operating requirement

Guidance

- G 2.7.3.4 This requirement is always applicable to the following cautionary aspects, which are specified in RIS-0758-CCS:
- 3-aspect caution
 - 4-aspect first caution (YY)
 - The outermost distant ON aspect.
- G 2.7.3.5 The minimum distance needed for a train that is moving at the permissible speed to stop at the limit of MA can be described using the following formula:
- G 2.7.3.6 Minimum stopping distance = $MRD + MSBD$, where MRD is the minimum readable distance of the signal displaying the first cautionary aspect and MSBD is the minimum signalling braking distance applicable to the signal spacing.
- G 2.7.3.7 The signal sighting assessment process set out in RIS-0737-CCS includes an assessment of the minimum readable distance (MRD) based on the minimum response time (MRT) for the driver to apply the brakes before the train passes the signal showing the cautionary aspect.
- G 2.7.3.8 GKRT0075 sets out the MSBD values that provide for technical compatibility of lineside signalling systems with train braking performance, including an allowance for the time taken for the brakes to be fully applied after the driver has initiated the brake command.
- G 2.7.3.9 It is good practice to position signals so that signal spacing exceeds the MSBD requirement, where the combination of infrastructure layout and headway requirements permit. Good practice on track circuit block (TCB) lines fitted with continuous colour light signalling is to position signals to achieve signal spacing that is between $MSBD + 10\%$ and $MSBD + 50\%$.
- G 2.7.3.10 Signal spacing that is less than $MSBD + 10\%$ is reviewed as part of the signal overrun risk assessment process.
- G 2.7.3.11 Signal spacing that exceeds $MSBD + 50\%$ is reviewed as part of the driveability assessment process.

2.7.4 Consistency of cautionary aspect sequence

- 2.7.4.1 Signals that form part of a cautionary aspect sequence shall show the same cautionary aspect each time the limit of movement authority (limit of MA) is denoted by the same stop signal.

Rationale

- G 2.7.4.2 Showing consistent cautionary aspect sequences supports the development and retention of train driver route knowledge and experience of the location of the limit of MA ahead of the train. Although some types of trains, in some environmental conditions, might be able to stop in a significantly shorter distance than the designed signal spacing provides for, varying the cautionary aspect sequence to accommodate better braking performance would increase signal overrun risk.

- G 2.7.4.3 Conformity with this requirement can be used to control the following driveability hazard precursor listed in section [1.3.2](#):

Inconsistent signal aspects and indications presented along the line

Guidance

- G 2.7.4.4 This requirement describes the aspect sequence from the viewpoint of the lineside signalling system controls. In the operational context, train drivers understand that the cautionary aspect they observe at successive signals is influenced by the time of signal route setting and the forward movement of a train in front.
- G 2.7.4.5 A different cautionary aspect sequence can be shown on alternative lines that approach a main stop signal. The design of each cautionary aspect sequence is influenced by the track layout and permissible speed profile on the approach to the signal.

2.8 Requirements for cautionary aspect sequences on TCB lines

2.8.1 Types of cautionary aspect sequence

- 2.8.1.1 On lines operated using the track circuit block system (TCB lines), the following cautionary aspect sequences shall be applied:
- 3-aspect sequence
 - 4-aspect sequence.
- 2.8.1.2 The signal spacing and signal aspect sequences at transitions between 3-aspect and 4-aspect sequences shall maintain conformity with [2.7.3](#).

Rationale

- G 2.8.1.3 Options [2.8.1.1 a\)](#) and [b\)](#) are available for application on TCB lines, which take account of the variable relationship between signal spacing, permissible speed and the headway capacity of the line. A greater range of options would increase the variability of signal aspects and their meaning, and consequently make the train driving task more difficult.
- G 2.8.1.4 Both options support conformity with [2.7.3](#). The signal position and signal aspects at transitions between 3-aspect and 4-aspect signalling potentially impact on conformity with that requirement.
- G 2.8.1.5 Conformity with these requirements can be used to control the following driveability hazard precursors listed in section [1.3.2](#):

Inconsistent signal aspects and indications presented along the line

Insufficient time for the train driver to comply with the operating requirement

Guidance on aspect sequence types

- G 2.8.1.6 The 3-aspect sequence and 4-aspect sequence are provided using colour light signals.
- G 2.8.1.7 Where multi-track lines are signalled in the same direction, a 4-aspect sequence and a 3-aspect sequence can be implemented on adjacent lines. Train movements between the adjacent lines are signalled using a cautionary aspect sequence transition that always provides the minimum signalling braking distance (MSBD), which can take account of the permissible speed at the crossover.
- G 2.8.1.8 Where bi-directional signalling is implemented on a line signalled using 4-aspect colour light signals for the predominant (normal) direction of traffic, the 3-aspect sequence can be used for movements in the opposite direction.
- G 2.8.1.9 The following considerations are relevant to both of these applications:
 - a) Parallel positioning of signals - refer to section [2.2.1](#)
 - b) Signal spacing requirements of 3-aspect signals that display the yellow and red aspects.
- G 2.8.1.10 Signal overrun risk assessment is used to confirm the acceptability of implementing or perpetuating a non-conforming aspect sequence.

Guidance on transitioning from a 3-aspect to a 4-aspect sequence

- G 2.8.1.11 Examples of where a 3-aspect to 4-aspect transition arises include:
 - a) At a boundary between 3-aspect and 4-aspect signalling in a plain line area
 - b) Where a line signalled using 3-aspect signalling joins a line signalled using 4-aspect signalling at a converging junction
 - c) Where a line signalled using 4-aspect signalling diverges from a line signalled using 3-aspect signalling.
- G 2.8.1.12 Frequent and numerous aspect sequence transitions increases train driver workload and therefore can adversely affect driveability. Where a sequence of transitions is necessary, it is good practice to provide at least three cycles of each aspect sequence between successive transitions.
- G 2.8.1.13 The following methods are available to conform with the requirements applicable to the cautionary aspect sequence at a transition from a 3-aspect sequence to a 4-aspect sequence:
 - a) Omit the stop aspect at the second 4-aspect signal
 - b) The first 4-aspect signal is positioned at least MSBD from the second 4-aspect signal and shows the 3-aspect caution when the second 4-aspect signal is showing the stop aspect
 - c) The first 4-aspect signal shows the main stop aspect until the train driver has passed the signal showing the last 3-aspect caution
 - d) At a slow speed converging junction, omit the 4-aspect first caution (see [G 2.8.3.14](#)).
- G 2.8.1.14 Each method is capable of providing the train driver with enough time (and distance) to comply with the limit of movement authority (limit of MA), taking account of the various infrastructure layouts and operational contexts on the GB mainline railway.

G 2.8.1.15 Method a) (see Figure 3) shows the first cautionary aspect at a location that is consistent with the aspect sequences at either side of the transition. This provides the following benefits:

- a) It maintains the correct aspect sequences. In this case the first 4-aspect signal does not show a single yellow aspect and the second 4-aspect signal is not a stop signal
- b) It avoids the increased signal overrun risk associated with the other methods.

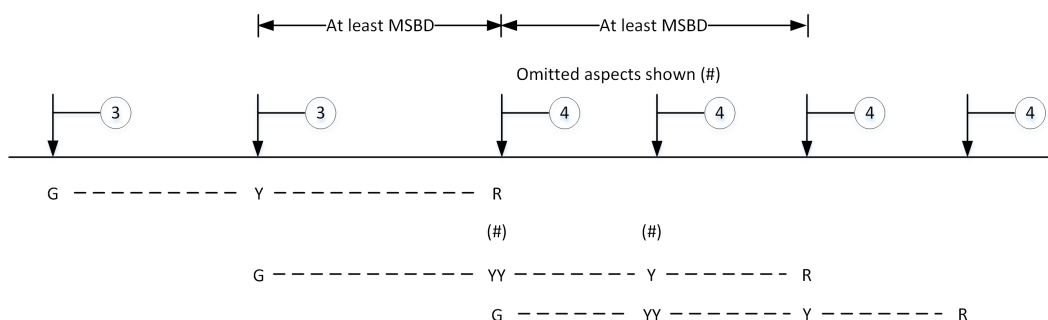

Figure 3: Example of a 3-aspect to 4-aspect transition omitting a main stop aspect

G 2.8.1.16 Method b) (see Figure 4) overlaps the 3-aspect sequence with the 4-aspect sequence. This has the potential to increase signal overrun risk because:

- a) The first 4-aspect signal shows the first caution for the next two stop signals, although the risk is partly controlled because the aspects have a different appearance
- b) Excess braking distance applies between the 4-aspect first caution (YY) and the main stop aspect. Generally, this does not result in an increased headway in the transition area, whereas the other methods do.

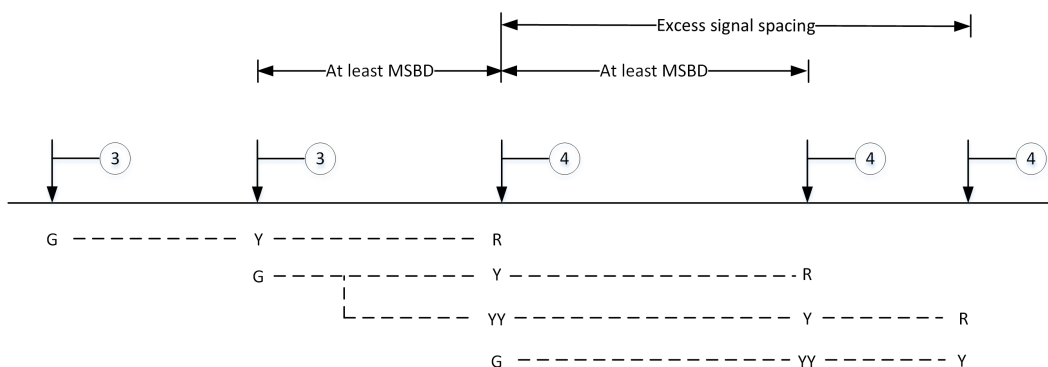

Figure 4: Example of a 3-aspect to 4-aspect transition with excess signal spacing

G 2.8.1.17 Method c) (see Figure 5) applies a delayed aspect to achieve compatibility between reduced signal spacing and the deceleration distance required to comply with the limit of MA. Method c) could result in an increased headway, which might be a significant factor unless the permissible speed is a low value. Examples of where method c) might be relevant are:

- a) Where the transition is located at a junction signal where the junction signal approach control from red aspect (MAR) sequence is applied

b) Where the transition is at a low speed converging junction.

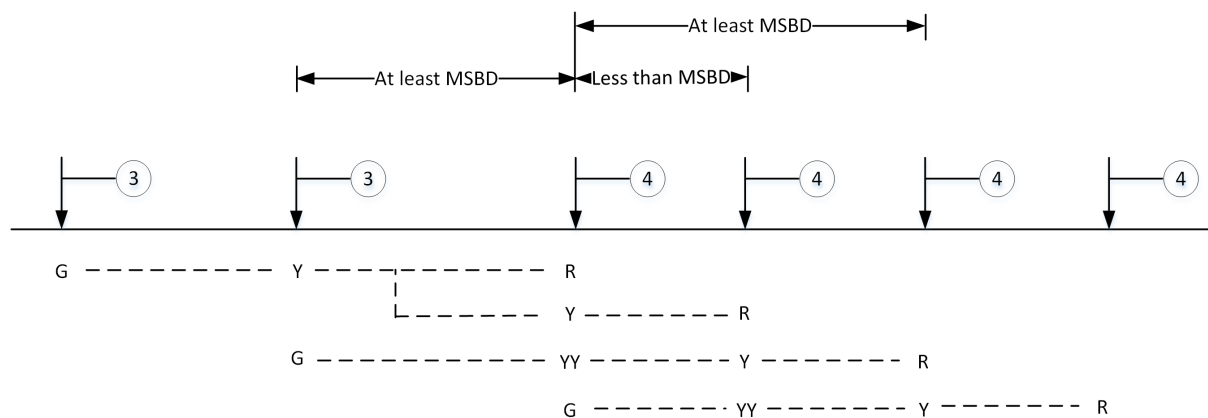

Figure 5: Example of applying an approach release from red control at a 3-aspect to 4-aspect transition

G 2.8.1.18 RIS-0386-CCS sets out requirements relevant to signal overrun risk evaluation and assessment.

Guidance on transitioning from a 4-aspect to a 3-aspect sequence

G 2.8.1.19 It is good practice to design the signalling system so that an isolated 3-aspect sequence is not shown on a line signalled using a 4-aspect sequence. This is to reduce the likelihood of signal passed at danger (SPAD) risk that arises when a train driver misinterprets which signal is showing the stop aspect at the limit of MA.

G 2.8.1.20 Signal spacing requirements for the first 3-aspect caution mean that there are no specific design solutions needed for a 4-aspect to 3-aspect sequence transition in plain line areas.

G 2.8.1.21 Where a 4-aspect to 3-aspect transition occurs at a 4-aspect junction signal (see Figure 6), the following arrangement is applied:

a) The first 3-aspect signal on the diverging route is located at least MSBD beyond the junction signal. The diverging route might be a parallel line on a multi-track railway, where 3-aspect signalling and 4-aspect signalling are provided on adjacent lines

b) The junction signal shows the 3-aspect caution (Y) when the first signal on the diverging route is displaying the stop aspect.

G 2.8.1.22 The arrangement means that a train will have enough time (and distance) to comply with the limit of MA beyond the junction on the diverging line.

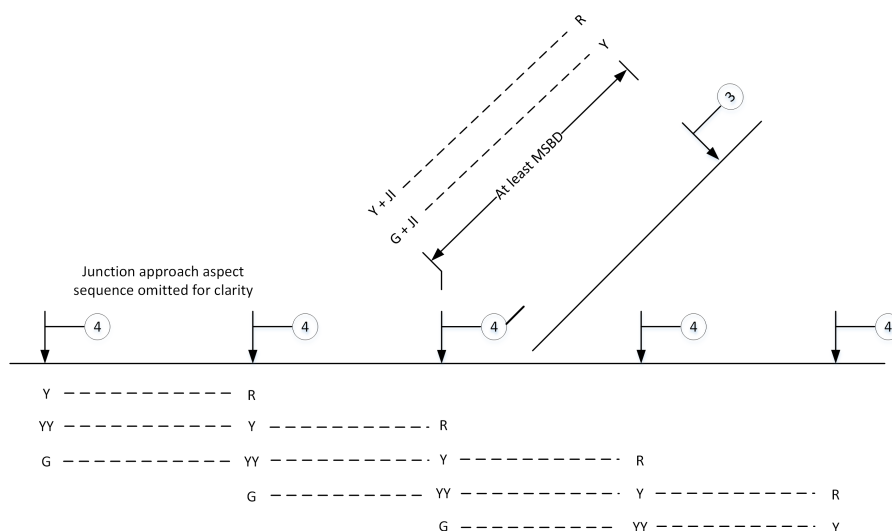

Figure 6: A 4-aspect to 3-aspect signalling transition at a diverging junction

G 2.8.1.23 Because MSBD is available between the junction signal and the first 3-aspect signal on the diverging route, the junction signal presents the 3-aspect caution when the limit of MA is at the first signal on the diverging route. Where the unrestricted (free) junction aspect (MAF) sequence applies, in this circumstance the junction approach signal can present a green aspect when the first signal on the diverging route is showing the 3-aspect caution (Y).

- G 2.8.1.24 It is good practice to review the following as part of the driveability assessment:
- The signal spacing from the junction signal to the first 3-aspect signal on the diverging route
 - The junction approach aspect sequence
 - The maximum attainable speed at the junction signal when the signal route is set for a diverging line
 - The permissible speed applicable at and beyond the junction.

2.8.2 3-aspect sequence

2.8.2.1 Where the 3-aspect sequence is applied, the main signal preceding the main stop aspect shall show the 3-aspect caution.

Rationale

G 2.8.2.2 The 3-aspect caution accurately reflects the limit of movement authority (limit of MA) at the next main stop signal.

G 2.8.2.3 Conformity with this requirement can be used to control the following driveability hazard precursor listed in section 1.3.2:

Poor accuracy of the provided information

Guidance

G 2.8.2.4 The train driver uses the 3-aspect caution to understand that the limit of MA is at the next signal. This informs the train driver's decision about when to apply the brake.

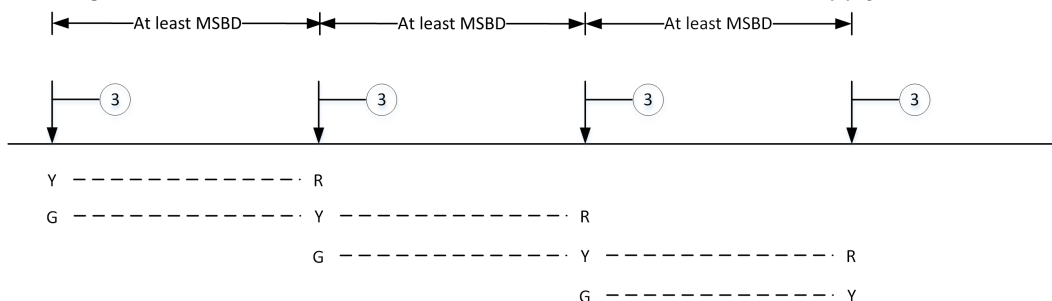

Figure 7: An example of a 3-aspect sequence presented by colour light signals

G 2.8.2.5 In Figure 7, 'G' denotes the unrestricted proceed aspect, 'Y' denotes the 3-aspect caution, 'R' denotes the main stop aspect and 'MSBD' denotes the availability of minimum signalling braking distance.

G 2.8.2.6 The distinction between the Y that denotes a '3-aspect caution' and a Y that denotes the '4-aspect single yellow caution' is not obvious to train drivers. This is acceptable because the first cautionary aspect always provides sufficient time (and distance) for the train to stop at the limit of MA.

G 2.8.2.7 Consecutive single yellow aspects within a 3-aspect sequence are avoided because the 4-aspect sequence is capable of providing the equivalent operational capacity enhancement.

G 2.8.2.8 Where the signal spacing is incompatible with the required minimum signalling braking distance (MSBD) and it is assessed that providing an isolated 4-aspect sequence is not appropriate, 'approach controlled from red aspect' controls can be applied to the signal that shows the 3-aspect caution.

2.8.3 4-aspect sequence

2.8.3.1 Where the 4-aspect sequence is applied, a sequence of two cautionary aspects shall be shown on the approach to the signal showing the main stop aspect (R), as follows:

- a) The first cautionary aspect shall be a double yellow (YY)
- b) The second cautionary aspect shall be a single yellow (Y)
- c) The signal showing the Y shall be located either:
 - i) At a distance from the main stop aspect that is at least 33% of the minimum signalling braking distance (MSBD) between the YY and the R, or
 - ii) Where there is a reduction in permissible speed between the YY and the R, at least MSBD from the R, calculated using the permissible speed applicable at the signal showing the Y.

Rationale

- G 2.8.3.2 The train driver uses the YY to understand that the limit of movement authority (limit of MA) is two signal sections away. This informs the decision about when to apply the brake. Further guidance on omitting the YY is provided in [page 44](#).
- G 2.8.3.3 After reading the cautionary aspect at the previous main signal, train drivers use the second cautionary aspect to confirm that the limit of MA has not changed. The Y accurately reflects the limit of MA at the next main stop signal.
- G 2.8.3.4 The distance from the Y to the R influences how much time the train driver has to regulate the speed of the train on the approach to the end of MA. If the train driver has correctly responded to the first cautionary aspect, the distance from the Y to the R always provides enough distance for the train to stop . Further guidance on positioning the Y is provided in [page 44](#).
- G 2.8.3.5 Conformity with this requirement can be used to control the following driveability hazard precursors listed in section [1.3.2](#):

Poor accuracy of the provided information
 Insufficient time for the train driver to comply with the operating requirement

Guidance on 4-aspect sequences

- G 2.8.3.6 Any main proceed aspect is relevant to starting a train.
- G 2.8.3.7 4-aspect signalling that conforms with these requirements is more driver-error tolerant than 3-aspect signalling. The additional cautionary aspect:
 - a) Provides another opportunity for the train driver to interpret the limit of MA ahead and take action to stop the train, albeit with less than MSBD available
 - b) Provides additional opportunity to stop a train in an emergency if the signal ahead is replaced to danger.
- G 2.8.3.8 On some lines, the 4-aspect sequence has been modified to incorporate additional cautionary aspects. Further guidance on this is provided in [page 45](#) and [page 46](#).

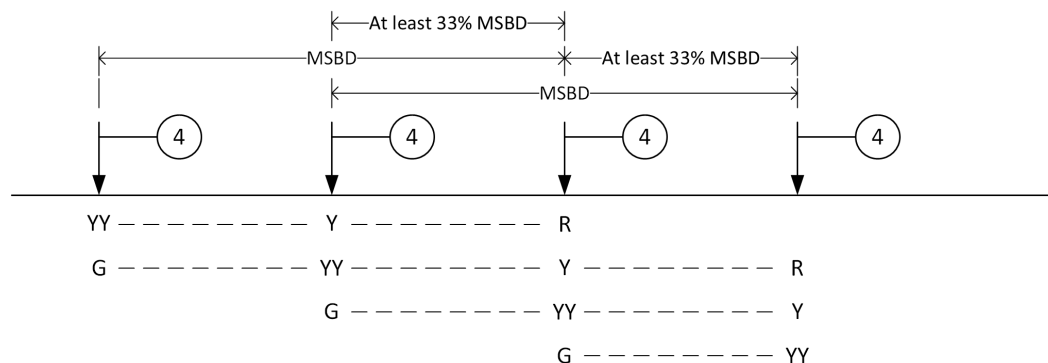

Figure 8: An example of a 4-aspect sequence

G 2.8.3.9 In Figure 8, 'G' denotes the unrestricted proceed aspect, 'YY' denotes the 4-aspect first caution, 'Y' denotes the 4-aspect single yellow caution (Y), 'R' denotes the main stop aspect, 'MSBD' denotes the availability of signalling braking distance and '33 % MSBD' denotes conformity with 2.8.3.1 c)i).

G 2.8.3.10 The GERT8000 Rule Book modules use the term 'preliminary caution' to describe the YY.

Guidance on positioning the 4-aspect single yellow caution

G 2.8.3.11 Where the permissible speed profile is similar throughout the aspect sequence, positioning the Y at least 33 % MSBD from the R helps to maintain consistency in signal spacing while allowing some flexibility in signal position.

G 2.8.3.12 If the permissible speed limit at the Y is significantly lower than the permissible speed limit at the YY, 33 % of the distance between the YY and R might significantly exceed the required train stopping distance. In this case the Y can be MSBD from the R, calculated at the lower permissible speed. This arrangement is reviewed during the driveability assessment because the impact on driveability may vary for different types of trains.

Guidance on mid-platform signals

G 2.8.3.13 Where a mid-platform signal is located less than 33 % MSBD from the platform exit signal, the permissible speed profile and signals are configured so that train drivers can easily identify which signal denotes the limit of MA and have enough time to stop the train. The following good practice is consistent with achieving this objective:

- a) The distance from the running-in platform ramp to the platform starting signal is greater than MSBD at the permissible speed
- b) The train driver can read the mid-platform signal aspect before the train passes the running-in platform ramp
- c) The train driver can read the platform starting signal aspect before the train passes the mid-platform signal.

Guidance on omitting the 4-aspect first caution

G 2.8.3.14 Showing a G instead of a YY can provide a cost-benefit through operating efficiencies and a reduction in signalling system cost where all trains start from rest at that signal, or approach it at a speed that is significantly less than the permissible speed limit applicable two signals ahead.

G 2.8.3.15 Examples of where this option might be applicable include:

- a) Where trains start from a terminal station, a bay platform or a siding (see Figure 9). Where this option is applied, the starting signal shows the G whenever the next signal ahead is showing a proceed aspect
- b) At a low speed converging junction where a line signalled with the 3-aspect sequence joins a 4-aspect signalled line at the junction. Where this option is applied, the 3-aspect signal protecting the converging junction shows the G whenever the next signal ahead is showing a proceed aspect.

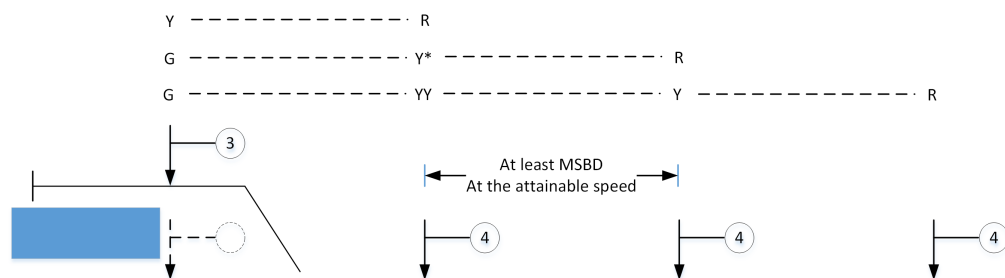

Figure 9: An example showing a 4-aspect sequence that omits the YY aspect for trains starting from a bay platform

G 2.8.3.16 Attainable speed data is used to confirm that the signal spacing between the signals showing the Y * and R aspects is compatible with the distance the train needs to conform with the limit of MA. GKRT0075 includes further guidance on using attainable speed data to inform decisions about signal spacing.

G 2.8.3.17 Where this option is applied at a terminal station, driveability is enhanced if MAs from all starting signals towards the same signal ahead apply this variation. At other locations this option may apply only to some MAs (for example, from a bay platform or a siding), while other MAs towards the same signal have the complete 4-aspect sequence.

G 2.8.3.18 The signal overrun risk assessment should take account of the fact that the second signal shows a first cautionary aspect (Y * and YY) for two successive stop signals.

Guidance on presenting consecutive YY aspects

G 2.8.3.19 At some locations a 4-aspect sequence incorporating consecutive YY aspects is implemented, with the aim of:

- Increasing the theoretical line capacity by providing additional but shorter signal sections
- Facilitating an increase in the permissible speed limit on an existing line, where an existing signal section does not support the increased MSBD requirement.

G 2.8.3.20 In either case the 4-aspect first caution YY is shown more than two signal sections before the stop aspect, to provide MSBD, and one or more additional YY aspects are shown between that signal and the Y caution. The information conveyed by an additional YY does not conform with RIS-0758-CCS and this potentially increases the likelihood of a signal overrun if:

- The driver is not able to interpret which YY aspects are less than MSBD from the stop aspect
- The same 4-aspect first caution (YY) can apply to more than one consecutive stop aspect.

G 2.8.3.21 The driveability assessment is applied to confirm that a signalling layout that incorporates consecutive YY aspects is driveable and the signal overrun risk assessment is applied to confirm that appropriate signal overrun risk controls are in place.

- G 2.8.3.22 If a non-standard 4-aspect sequence incorporates a junction signal that is not approach controlled from red, the likelihood of a signal overrun at the first stop signal on the diverging route can be controlled by positioning signals so that the distance from the diverging junction to the first stop signal on the diverging route equals or exceeds the minimum train stopping distance for trains moving at the permissible speed limit applicable at the junction.
- G 2.8.3.23 RSSB research reports T998-1 and T998-2 provide further guidance on the implications of presenting additional YY aspects to increase capacity.

Guidance on presenting consecutive Y aspects

- G 2.8.3.24 At some locations a closing-up signal or a mid-platform signal is used to enhance the operational capacity of a busy station or junction layout.
- G 2.8.3.25 Where a signal is to be positioned so that a Y is shown at a distance from the limit of MA that would be non-compliant with [2.8.3.1 c](#)), two alternative solutions are available:
- a) That signal is controlled to present the main stop aspect until the approaching train has passed the previous signal showing the 4-aspect single yellow caution
 - b) A closing-up signal is provided to show an additional Y aspect between a compliant 4-aspect single yellow caution and the main stop aspect.
- G 2.8.3.26 In either case, the signalling system presents the YY at a compliant distance from the main stop aspect.
- G 2.8.3.27 A signal that is approach controlled from red has the potential to increase signal overrun risk due to train driver expectation of a proceed aspect.
- G 2.8.3.28 The information conveyed by a closing up Y aspect does not conform with RIS-0758-CCS and this potentially increases the likelihood of a signal overrun if:
- a) The driver is not able to interpret which Y is less than 33 % MSBD from the stop aspect
 - b) The same YY can apply to more than one consecutive stop aspect.
- G 2.8.3.29 Driveability assessment is used to confirm that a signalling layout that incorporates consecutive Y aspects is driveable and the signal overrun risk assessment is applied to confirm that appropriate signal overrun risk controls are in place.

2.9 Requirements for cautionary aspect sequences on non-TCB lines

2.9.1 Application of a distant aspect sequence

- 2.9.1.1 In non-track circuit block (non-TCB) signalling areas, a distant signal shall show the distant ON aspect when an associated block or non-block stop signal denotes the limit of movement authority (limit of MA).

Rationale

- G 2.9.1.2 The distant ON aspect supports conformity with [2.7.2](#). A greater range of options would increase the variability of signal aspects and their meaning, and consequently make the train driving task more difficult.

- G 2.9.1.3 Conformity with this requirement can be used to control the following driveability hazard precursor listed in section [1.3.2](#):

Inconsistent signal aspects and indications presented along the line

Guidance

- G 2.9.1.4 Non-TCB areas include the following systems for issuing, not all of which incorporate worked signals:
- a) Absolute block (AB)
 - b) Tokenless block (TB)
 - c) Electric token block (ETB)
 - d) No-signaller token block (NST)
 - e) No-signaller token block-remote (NSTR)
 - f) One-train system with staff
 - g) One-train system without staff
 - h) Radio electronic token block (RETB).
- G 2.9.1.5 The train driver uses the distant ON aspect to understand that the limit of MA is at the next stop signal. This information informs the decision about when to apply the brake.
- G 2.9.1.6 GKGNO655 provides further guidance about block and non-block signals in non-TCB signalling areas.
- G 2.9.1.7 RIS-0758-CCS sets out requirements for the appearance and meaning of distant ON aspects using semaphore signals, colour light signals or fixed distant boards.

2.9.2 Showing a distant OFF aspect on non-TCB lines

- 2.9.2.1 A distant signal shall show the distant OFF aspect only if one of the following applies:
- a) All semaphore stop signals to which it applies are showing a main proceed (OFF) aspect, or
 - b) The next stop signal ahead is a colour light home signal showing a yellow OFF aspect, and minimum signalling braking distance (MSBD) is available between that home signal and the next main stop signal ahead.

Rationale

- G 2.9.2.2 Where clause [2.9.2.1 a\)](#) applies, the distant OFF aspect accurately reflects the availability of a movement authority (MA) beyond the next home and section signals or non-block stop signal. There is no need for the train to prepare to stop at the end of this block section or signal section.
- G 2.9.2.3 Where clause [2.9.2.1 b\)](#) applies, the cautionary aspect shown by the next stop signal will provide the train with enough time (and distance) to comply with the limit of MA.
- G 2.9.2.4 Conformity with this requirement can be used to control the following driveability hazard precursors listed in section [1.3.2](#):

Poor accuracy of the provided information
Insufficient time for the train driver to comply with the operating requirement

Guidance

- G 2.9.2.5 Where clause [2.9.2.1b](#)) applies, the resulting cautionary aspect sequence is similar to track circuit block (TCB) 3-aspect signalling.

2.9.3 Provision of additional semaphore distant arms

- 2.9.3.1 In non-track circuit block (non-TCB) signalling areas where semaphore signals are provided, a semaphore distant arm shall also be provided at all main stop signals between the outermost distant signal and the first stop signal to which it applies.

Rationale

- G 2.9.3.2 The repeat distant arm reminds the train driver that the train is still approaching the stop signal to which the distant signal applies.
- G 2.9.3.3 Conformity with this requirement can be used to control the following driveability hazard precursor listed in section [1.3.2](#):

Some provided information is not current

Guidance

- G 2.9.3.4 This requirement is applicable where the outermost distant signal arm is located under a home signal controlled by the previous signal box. In this case a distant arm is also provided at all subsequent home signals and the section signal controlled by the previous signal box.
- G 2.9.3.5 RIS-0758-CCS sets out further requirements for combined semaphore stop and distant signals.

2.9.4 Controlled release of preceding home signal aspects

- 2.9.4.1 In non-track circuit block (non-TCB) signalling areas when the section signal, or a home signal within station limits, is showing the main stop aspect, the previous home signal shall show the main stop aspect until the approaching train is assumed to be within 180 m of that signal, unless both of the following apply:
- Minimum signalling braking distance (MSBD) is available between that home signal and the next main stop signal, and
 - That home signal is a colour light signal showing a cautionary aspect.

Rationale

- G 2.9.4.2 The distant signal ON aspect is positioned at least MSBD from the next main stop signal and informs the train driver that the limit of movement authority (limit of MA)

is at that signal . There is no requirement for MSBD between successive stop signals within station limits.

G 2.9.4.3 Where the distance from a home signal to the next stop signal within station limits is less than MSBD, delaying the home signal OFF aspect until the train is almost at the end of its MA is intended to provide the train driver with enough time (and distance) to comply with the limit of MA at the next stop signal ahead.

G 2.9.4.4 180 m has been historically applied as the signal approach release point in non-TCB areas.

G 2.9.4.5 Where the criteria described in [2.9.4.1 a\)](#) and [b\)](#) apply:

a) The availability of MSBD between the home signal and the next stop signal ahead means that the train driver has enough time (and distance) to stop the train at the limit of MA from the permissible speed, and

b) The cautionary aspect informs the train driver that the train is approaching the limit of MA and that there is sufficient distance to stop the train.

G 2.9.4.6 Conformity with this requirement can be used to control the following driveability hazard precursor listed in section [1.3.2](#):

Insufficient time for the train driver to comply with the operating requirement

Guidance

G 2.9.4.7 Conformity with this requirement can be achieved using either interlocking controls or application of operating rules. The use of operating rules to implement this control is dependent on the capability of the signaller to confirm that the train is within 180 m of the signal before it is cleared to a proceed aspect.

G 2.9.4.8 GKGNO655 provides further guidance relevant to the layout of stop signals in non-TCB signalling areas (home signals and section signals).

G 2.9.4.9 The application of semaphore home and section signals can result in clusters of stop signals separated by long block sections and signal aspect sequences that might be unfamiliar to some train drivers. It is good practice to review inconsistent signal spacing as part of a driveability assessment in accordance with RIS-0713-CCS.

Part 3 Requirements for Indication of Route

3.1 Requirements to indicate which line the MA applies to

3.1.1 Provision of route-ing information

3.1.1.1 The lineside signalling system shall provide route-ing information when either of the following is applicable:

- a) The movement authority (MA) at a main junction signal is for a train movement towards a diverging line, or
- b) The MA is for a movement towards a signal that denotes a limit of shunt.

Rationale

G 3.1.1.2 A diverging junction provides a means of directing a train either along the line currently being used or an alternative line (a divergence). Train drivers use route-ing information to understand which line the MA applies to (and therefore the next signal), and the permissible speed limit applicable at the junction.

G 3.1.1.3 A limit of shunt denotes a limit of MA on a running line where other trains use full MAs applicable in the opposite direction. The route-ing information contributes to the control of signal overrun risk by reinforcing the driver's understanding that the movement is towards the limit of shunt.

G 3.1.1.4 Conformity with this requirement can be used to control the following driveability hazard precursor listed in section 1.3.2:

Information provided by the signalling system is not complete

Guidance

G 3.1.1.5 Further requirements and guidance on the indication of an MA towards a limit of shunt are set out in section 3.2.1.

G 3.1.1.6 An indication of route can be provided at other locations; for example, where the straightest line beyond a set of facing points is not signalled, an indication of route can reinforce train driver learning and route knowledge retention. Signal sighting assessment and a driveability assessment are used to confirm that the information provided by the lineside signalling system is sufficient to inform the train driving task at facing points.

G 3.1.1.7 The decision about indicating the line to which the MA applies takes account of the contribution to interpretability of train driver's route knowledge and experience. It is assumed that train drivers will interpret that the principal route is set when no route indication is presented.

G 3.1.1.8 The lineside signalling system can provide the following types of route-ing information to train drivers:

- a) Directional information, using a junction indication
- b) Line or destination information, using an alphanumeric route indication

- c) A combination of both.
- G 3.1.1.9 Different types and combinations of route indications can be shown for different signal routes from the same junction signal.
- G 3.1.1.10 In colour light signalling areas, it is good practice to show a junction indication at a main junction signal, unless showing an alphanumeric route indication would improve interpretability or driveability, or provide a risk reduction.
- G 3.1.1.11 It is good practice to show an alphanumeric route indication in the following circumstances:
- a) Where a destination is a buffer stop. Where there are no through lines beyond the signal, an alphanumeric indication is shown with every proceed aspect
 - b) Where the track layout includes a mix of destination types. At a station, an alphanumeric route indication can be used to differentiate between platform lines and non-platform lines, through platforms and terminal platforms, and platforms with substantially different lengths
 - c) Where the junction signal is a starting signal for a terminal platform, or a start-back signal for a through platform, or any other main signal that is not approached using a main proceed aspect. In this case, an alphanumeric indication is shown with every proceed aspect
 - d) Where the junction signal is located at the exit from a yard, depot or siding, and it is not approached using a main proceed aspect
 - e) Where there are multiple left-hand or right-hand divergences, or where the first diverging line beyond the junction signal has a lower permissible speed than other diverging lines from the same signal
 - f) Where there are physical restrictions that preclude the use of junction indicator (JI) equipment
 - g) Where the route indications available using a JI are not compatible with the junction layout; for example, a diverging line crosses, on the level, one or more lines that are beyond the same junction signal.
- G 3.1.1.12 In complex areas, showing a junction indication and an alphanumeric route indication together can improve driveability. The junction indication enables the driver to interpret that the MA applies to a left-hand or right-hand diverging line at the junction before the alphanumeric route indication is used to interpret the destination. In such cases, it is good practice to assess the over-speed risk arising from the permissible speed profile on each line beyond the signal.
- G 3.1.1.13 RIS-0737-CCS sets out the requirements for assessing the readable distance of signals that show route indications. The readability performance of alphanumeric route indicator equipment limits their use to applications with lower permissible speeds than JI equipment. Product acceptance certificates set out the application constraints that restrict the use of standard alphanumeric route indicator (SARI) and miniature alphanumeric route indicator (MARI) equipment.
- G 3.1.1.14 When route-ing information is provided as a combination of junction indication and alphanumeric indication, driveability is supported when it is implemented using a JI and a SARI.

- G 3.1.1.15 When route-ing information is provided as an alphanumeric route indication, it is implemented using a SARI or a MARI.
- G 3.1.1.16 RIS-0758-CCS sets out further requirements for the signal aspects and indications that show an indication of route, including:
- Junction indications
 - Alphanumeric route indications
 - Junction flashing aspects
 - Junction splitting distant aspects
 - Semaphore signal arm combinations
 - Splitting banner repeater indications
 - Banner junction indications
 - Preliminary route indications.

3.1.2 Alphanumeric route indications

Guidance

- G 3.1.2.1 Showing an alphanumeric route indication supports conformity with requirement [3.1.1.1](#); for example, where a movement authority (MA) is provided by a position light signal. The alphanumeric indication codifies the line identity or describes the destination to which the MA applies.
- G 3.1.2.2 RIS-0758-CCS sets out requirements for the appearance and meaning of alphanumeric route indications, and the signal aspects that they can be shown with.
- G 3.1.2.3 RIS-0737-CCS sets out requirements for assessing the readability and interpretability of alphanumeric route indications and guidance on positioning the indicator relative to the signal head.
- G 3.1.2.4 RIS-0713-CCS sets out requirements for assessing the application of alphanumeric route indications to confirm that train drivers can interpret which line or destination the MA applies to, and in some cases, whether the MA is for a permissive movement or a shunting operation.
- G 3.1.2.5 Train driver learning and route knowledge retention is supported if:
- Different alphanumeric route indications are used to indicate different lines or destinations (or sets of destinations) within the same geographic area
 - Where a train movement towards a common destination can be made from more than one signal, those signals fitted with an alphanumeric route indicator show the same, or similar, alphanumeric indications to indicate that destination. This does not mean that all signals that provide an MA towards a common destination have to be fitted with an alphanumeric route indicator. A main signal can show a junction indication when other signals within the layout show an alphanumeric route indication towards the same destination
 - Where a main junction signal is fitted with a standard alphanumeric route indicator (SARI) and a miniature alphanumeric route indicator (MARI), both of which provide an MA towards the same destination, a similar indication is used to indicate a destination that is common to a full MA and a permissive or shunt MA.

G 3.1.2.6 In this context, the term 'similar' is used to describe alphanumeric route indications that are different but which incorporate one or more of the same characters to indicate an MA towards the same line or destination; for example, 'SDG' and 'S' for MAs from alternative signals towards a siding. In such cases, the driveability assessment confirms that a similar but different route indication is acceptable.

3.1.3 Position of initial route information

3.1.3.1 The location of the first indication of signalled route shall provide the train driver with enough time (and distance) to comply with the permissible speed limit applicable at the junction.

Rationale

G 3.1.3.2 The permissible speed limits applicable at a diverging junction can be different on each line. The train driver uses the indication of signalled route to confirm which line the MA applies to and which permissible speed limit applies. If the first indication of signalled route is too close to the junction, the driver might not have enough time (and distance) to comply with the permissible speed.

G 3.1.3.3 Conformity with this requirement can be used to control the following driveability hazard precursor listed in section 1.3.2:

Insufficient time for the train driver to comply with the operating requirement

Guidance

G 3.1.3.4 Conformity with requirement 3.1.3.1 is achieved if the distance from the first indication of signalled route to the diverging junction is greater than the distance needed for the train to decelerate.

G 3.1.3.5 Conformity with requirement 3.1.3.1 considers all types of trains authorised to use the lineside signalling system, all lines beyond the junction and all the permissible speed limits that apply. Where attainable speed is used to determine the distance from the first indication of signalled route to the diverging junction, the acceleration calculations are based on the performance characteristics of trains authorised to use the lineside signalling system and recorded as an assumption in the project record.

G 3.1.3.6 Providing the train driver with advance route-ing information means that it is not necessary to always apply the MAR sequence (Junction signal approach controlled from red aspect).

G 3.1.3.7 In 3-aspect signalled areas, the following junction aspect sequences provide route-ing information at least minimum signalling braking distance (MSBD) from the junction signal:

- a) MAY-FA3 (junction signal approach controlled from single yellow aspect with a flashing single yellow aspect at the previous signal). Section 3.9.1 provides further guidance on using MAY-FA3.
- b) MAF-SD (free junction signal aspect with a splitting distant proceed aspect at the previous signal). Section 3.11.1 provides further guidance on using MAF-SD.

- G 3.1.3.8 In 4-aspect signalled areas, MAY-FA4 (junction signal approach controlled from single yellow with a flashing 4-aspect sequence at the previous two signals) provides route-ing information at least MSBD from the junction signal when the flashing YY is shown; if the non-flashing YY is shown, the train should be preparing to stop at the junction signal. Section 3.9.1 provides further guidance on using MAY-FA4.
- G 3.1.3.9 The following junction aspect sequences provide the route-ing information only when the junction signal route indication is interpreted:
- a) MAF (free junction signal aspect). Section 3.8 provides further guidance on using MAF
 - b) MAY-YY (junction signal approach controlled from a single yellow aspect with a YY at the previous signal). Section 3.10.1 provides further guidance on using MAY-YY.
- G 3.1.3.10 If the distance from the first indication of signalled route to the diverging junction is less than the distance needed for the train to decelerate, the following alternative mitigations could be applied:
- a) The reduction of train speed resulting from the approach control applied to the junction signal proceed aspect (for example, the delayed step-up of the single yellow aspect associated with MAY-YY)
 - b) Any additional time that the required readable distance (RRD) provides the train driver to respond to the indication of signalled route relative to the assessed minimum readable distance (MRD) for that signal or indicator. The MRD and RRD for lineside signalling assets is assessed and recorded by the signal sighting committee. The MRD of an asset provides train drivers with enough time to read, interpret and act upon the presented signal aspect or indication. If the RRD is greater than the MRD, the difference provides some additional time.
- G 3.1.3.11 A preliminary route indicator (PRI) can be used to provide route-ing information further away from the junction so that the driver has more time to comply with the operating requirement. Section 3.5.1 provides further guidance on the application of PRIs.

3.1.4 Maximum number of routes applicable to one route indication

- 3.1.4.1 The indication of signalled route shown by a signal or indicator shall always apply to the same diverging junction and line.

Rationale

- G 3.1.4.2 Providing route-ing information applicable to more than one junction could mislead a train driver into misinterpreting which junction or line the information applies to.
- G 3.1.4.3 Conformity with this requirement can be used to control the following driveability hazard precursor listed in section 1.3.2:

Poor interpretability

Guidance

- G 3.1.4.4 One diverging junction can incorporate any number of facing points in one signal section; for example:
- a) A single crossover
 - b) Multiple crossovers or facing points within a station approach
 - c) A facing point into a loop line, depot or siding
 - d) Multiple facing points into a fan of sidings.
- G 3.1.4.5 Successive facing points that are separated by main junction signals or independent shunting signals are separate diverging junctions.
- G 3.1.4.6 This requirement and the requirements for signal aspect and route indication combinations in RIS-0758-CCS prohibit the following display combinations:
- a) A route indication with a junction flashing aspect
 - b) A route indication with a junction splitting distant aspect
 - c) A flashing aspect presented as part of a junction splitting distant aspect
 - d) An arrow indication with a junction signal aspect
 - e) An arrow indication with a splitting banner repeater indication
 - f) Multiple arrow indications for different junctions at the same location.

3.1.5 Consistency of route indications

- 3.1.5.1 A junction signal shall show the same indication of signalled route each time the same type of movement authority (MA) is available on the same line beyond the diverging junction.

Rationale

- G 3.1.5.2 The indication of signalled route is used by train drivers, in combination with route knowledge and experience, to interpret which line the MA applies to. A variety of route indications would increase train driver workload.
- G 3.1.5.3 Conformity with this requirement can be used to control the following driveability hazard precursor listed in section 1.3.2:

Inconsistent signal aspects and indications presented along the line

Guidance

- G 3.1.5.4 No guidance is provided.

3.2 Requirements for indication of route with a shunt MA

3.2.1 Routeing information for an MA towards a limit of shunt

- 3.2.1.1 An alphanumeric route indication incorporating the character 'X' shall be shown when the movement authority (MA) is for a train movement towards a limit of shunt.

Rationale

- G 3.2.1.2 The consistent application of the 'X' indication reinforces train driver learning and route knowledge retention.
- G 3.2.1.3 Conformity with this requirement can be used to control the following driveability hazard precursors listed in section 1.3.2:

Poor interpretability
Inconsistent signal aspects and indications presented along the line

Guidance

- G 3.2.1.4 This requirement is applicable to those signals that provide MAs towards a limit of shunt, including those from signals that have only one shunt class route.
- G 3.2.1.5 If a signal can provide an MA towards more than one limit of shunt, additional characters can supplement the 'X' to identify which signalled route is set. If there is only one 'X' route, 'X' alone would be sufficient and additional characters are an option to assist drivers' understanding.
- G 3.2.1.6 RIS-0758-CCS provides further guidance on showing the 'X' indication; for example:
 - a) Where an MA applies to a line designated as 'Line X'
 - b) To reinforce train drivers' understanding that the MA applies in the opposite direction to the predominant flow of traffic on a line that has bi-directional signalling. A junction indicator or an alphanumeric route indication can be shown with a main proceed aspect that applies in the opposite direction.

3.2.2 Route-ing information with a shunt MA

- 3.2.2.1 An indication of signalled route shall be shown with the shunt aspect, unless one of the following criteria is applicable:
 - a) The shunt movement authority (shunt MA) always applies to the same line and does not end at a limit of shunt, or
 - b) All of the shunt MAs from that signal are towards sidings that have similar characteristics.
- 3.2.2.2 A main signal shall show an indication of signalled route with the shunt aspect if the signal can also show a calling-on aspect for an on-sight MA.

Rationale

- G 3.2.2.3 The information provided by the signalling system should be complete in terms of what is needed for the train driver to understand the limits of the shunt MA and distinguish it from an on-sight MA.
- G 3.2.2.4 Conformity with these requirements can be used to control the following driveability hazard precursor listed in section 1.3.2:

Information provided by the signalling system is not complete

Guidance

- G 3.2.2.5 If the driving task is similar irrespective of the siding towards which the shunting movement will take place, the shunt aspect on its own can provide sufficient information.
- G 3.2.2.6 Risk assessment is used to identify and control any safety hazards arising from a decision to omit the indication of route from an independent shunting signal where there is more than one shunt class route.
- G 3.2.2.7 Although it is good practice at most locations to show separate route indications for each MA at a signal, legacy practice on the GB mainline railway is to show a common route indication for shunt MAs where the lines they apply to are similar in length and have similar technical compatibility characteristics.

3.3 Route-ing information with an on-sight MA

- 3.3.1 An indication of signalled route shall be shown with the permissive aspect, unless there is only one signalled line beyond that signal and there is no need for the train driver to distinguish whether the on-sight movement authority (on-sight MA) is valid for a passenger train.

Rationale

- G 3.3.2 The information provided by the signalling system should be complete in terms of what is needed for the train driver to understand the line on which the on-sight MA applies. Train drivers also use the indication of signalled route to confirm that the on-sight MA is valid for the train being operated.
- G 3.3.3 Conformity with this requirement can be used to control the following driveability hazard precursors listed in section [1.3.2](#):

Information provided by the signalling system is not complete

Provided information is not relevant to some trains

Guidance

- G 3.3.4 Further guidance on showing a position light aspect at a main stop signal is set out in section [2.5.1](#).

3.4 Requirements for indication of route with a main proceed aspect

3.4.1 Junction signal position

Guidance on the distance from a junction signal to a diverging junction

G 3.4.1.1 The train driving task at a diverging junction includes:

- a) Interpreting the indication of signalled route to confirm which line or destination the movement authority (MA) applies to
- b) Interpreting a lineside operational sign to confirm which permissible speed is applicable at the junction, and
- c) Controlling the speed of the train to comply with the permissible speed limit and MA beyond the junction.

G 3.4.1.2 The distance from the junction signal to the diverging junction influences how much time is available to fulfil the train driving task. The potential for distraction away from the train driving task increases if the time available significantly exceeds the time needed. The likelihood of distraction could increase if the junction signal is a long way from the junction or if a station platform means that the train stops after passing the junction signal before reaching the junction.

G 3.4.1.3 The driveability assessment is used to confirm that the distance between a junction signal and the diverging junction is acceptable in terms of the likelihood of the train exceeding the permissible speed limit at the junction.

G 3.4.1.4 The following criteria have been historically applied to junction signals:

- a) The junction signal is no more than 800 m from the first set of facing points at the junction, unless one of the following is applicable:
 - i) The facing points are operated from a ground frame
 - ii) The junction signal is positioned parallel with other stop signals, one of which is positioned within 800 m of a set of facing points and there are other factors that prevent the positioning of stop signals closer to the junction
 - iii) The facing points are always set in the same position for facing moves from the stop signal
 - iv) The facing points are secured out of use
 - v) A distance temporarily greater than 800 m is associated with planned engineering stage-works, and details of the excess distance are published in the operating notices.

G 3.4.1.5 Risk assessment has been used to justify a junction signal positioned more than 800 m from the diverging junction. Mitigating factors have included:

- a) The visibility of the junction after the train has passed the junction signal
- b) The permissible speed profile between the junction signal and the junction
- c) The permissible speed limits at the junction
- d) The signal aspect sequence though the junction area
- e) The consistency of route setting at the junction
- f) The absence of potential distractions.

3.4.2 Indication of signalled route at a main junction signal

3.4.2.1 A main junction signal shall show an indication of route with a main proceed aspect that applies to a diverging line.

Rationale

G 3.4.2.2 The information provided by the lineside signalling system should be complete in terms of what is needed for the train driver to understand the line on which the MA applies.

G 3.4.2.3 Conformity with this requirement can be used to control the following driveability hazard precursor listed in section [1.3.2](#):

Information provided by the signalling system is not complete

Guidance

G 3.4.2.4 An indication can be shown for every signalled route at a diverging junction, including the principal signalled route.

G 3.4.2.5 Where a junction signal is fitted with a junction indicator, where no route indication is shown for the principal signalled route, train drivers use route knowledge and previous experience to interpret which line the MA applies to and which permissible speed limit applies.

G 3.4.2.6 The signal sighting assessment of a junction signal includes spatial compatibility with the track layout. A signal sighting committee or a signalling layout assessment report might recommend that route indications are provided for all signalled routes at a junction to reinforce the train driver's understanding. The following are examples of where this might apply:

- a) Where there is a line that is suitable for designation as the principal signalled route but it is not visibly obvious to train drivers
- b) Where no line is particularly suitable for designation as the principal signalled route
- c) Where the junction signal does not provide an MA towards the line that appears to be the principal signal route.

G 3.4.2.7 Where the line designated as the principal signalled route is not visibly obvious to drivers, it is good practice to show a junction aspect sequence for that signalled route.

G 3.4.2.8 A semaphore junction signal can convey the route-ing information using a positional combination of stop arms or an alphanumeric route indication, or both.

3.4.3 When the route indication is presented

3.4.3.1 A main junction signal shall show an indication of signalled route for a main proceed aspect only when the signal is ready to clear.

Rationale

- G 3.4.3.2 The indication of signalled route is intended to help the train driver interpret the line to which the movement authority (MA) applies. Showing the indication before the MA is provided would increase the likelihood of the train driver anticipating the MA and starting the train before reading the proceed aspect.
- G 3.4.3.3 Conformity with this requirement can be used to control the following driveability hazard precursor listed in section 1.3.2:

Poor interpretability

Guidance

- G 3.4.3.4 Section 2.1.3 provides guidance on using lamp proving functionality as a mis-routing risk mitigation measure.
- G 3.4.3.5 RIS-0758-CCS sets out further requirements relevant to signal aspect and route indication combinations and route indication proving controls.

3.4.4 Interpretability of route-ing information at a main junction signal

- 3.4.4.1 When a main proceed aspect is shown by a junction signal, the route-ing information shall be interpretable from the normal driving position when the main proceed aspect becomes visible.

Rationale

- G 3.4.4.2 If the route-ing information is either not interpretable when the train driver reads the main proceed aspect, or is provided after the driver has decided which line the movement authority (MA) applies to, the train might exceed the permissible speed limit at the junction.
- G 3.4.4.3 Conformity with this requirement can be used to control the following driveability hazard precursor listed in section 1.3.2:

Poor interpretability

Guidance

- G 3.4.4.4 Conformity with this requirement can be achieved using any of the following methods:
- Undertaking a signal sighting assessment to confirm that the visibility or readability of the route indicator means that train drivers will be able to interpret that the MA applied to a diverging line when the junction signal main proceed aspect becomes visible.
 - Providing any of the following, configured so that the train driver can obtain route-ing information before the junction signal main proceed aspect can be interpreted:
 - A splitting banner repeater indication

- ii) A banner junction indication
 - iii) A preliminary route indicator (PRI) arrow indication (subject to confirmation of readability)
 - iv) The MAY-FA3 sequence (junction signal approach controlled from a single yellow aspect with a flashing single yellow aspect at the previous signal)
 - v) MAY-FA4 sequence (junction signal approach controlled from a single yellow aspect with a flashing 4-aspect sequence at the previous two signals)
 - vi) MAF-SD sequence (free junction signal aspect with a splitting distant proceed aspect at the previous signal)
- c) Providing the MAR sequence (junction signal approach controlled from red) and delaying the junction signal proceed aspect until the driver can interpret the route indication.

G 3.4.4.5 The provision of route-ing information takes account of both of the following scenarios:

- a) When the main proceed aspect at the junction signal is shown before the train passes the junction approach signal
- b) When the main proceed aspect at the junction signal is shown after the train passes the junction approach signal.

G 3.4.4.6 Further constraints applicable to junction approach aspect sequences are set out in sections [3.7.1](#), [3.9.1](#) and [3.11.1](#).

G 3.4.4.7 It is good practice to show the unrestricted junction signal proceed aspect as soon as conformity with requirement [3.4.4.1](#) is achieved so that the AWS indication reflects the MA that is actually available.

G 3.4.4.8 RIS-0737-CCS sets out further requirements for signal sighting assessment, and guidance on when it is acceptable to use route indication visibility to achieve the required readable distance (RRD).

3.4.5 Showing the same indication of route for alternative paths

3.4.5.1 A main junction signal shall show an indication of signalled route that applies to more than one line or destination only if all of the following criteria apply:

- a) The same indication of signalled route is shown for alternative wheeled paths towards a common destination
- b) The permissible speed limit profile on the alternative paths is similar, and
- c) The alternative paths have similar technical compatibility characteristics.

Rationale

G 3.4.5.2 Train drivers use the indication of signalled route to interpret which line the movement authority (MA) applies to. Where the same indication of signalled route is used for alternative paths towards the same destination, the information provided needs to be sufficient for the driver to understand the profile of the MA.

G 3.4.5.3 Conformity with this requirement can be used to control the following driveability hazard precursor listed in section [1.3.2](#):

Poor interpretability

Guidance

- G 3.4.5.4 Where the complexity of the track layout means that providing a separate indication of route for alternative paths towards the same destination is not feasible, the same indication can be shared by the alternative paths if the operating parameters mean that the train driving task is similar irrespective of which path the train will use. A similar permissible speed profile presumes a permissible speed limit differential of 10 mph or less.
- G 3.4.5.5 The driveability of MAs with alternative paths is influenced by the relative positions of points and permissible speed limit changes. The impact on the train driving task is reviewed as part of the driveability assessment.
- G 3.4.5.6 Figures 10 and 11 are two examples where alternative signal routes can be set towards towards platform 2. If alternative wheeled paths have different permissible speed limit profiles, showing a different junction approach aspect sequence for each can help train drivers interpret which path is set and understand which permissible speed limit profile applies.
- G 3.4.5.7 The first example in Figure 10 implements a junction indication for the first higher speed route and an alphanumeric route indicator with an approach controlled aspect for the second lower speed route. The second example in Figure 11 implements an alphanumeric route indicator so that the first higher speed route is indicated as '2A' and the second lower speed route is indicated as '2B' with an approach-controlled aspect.

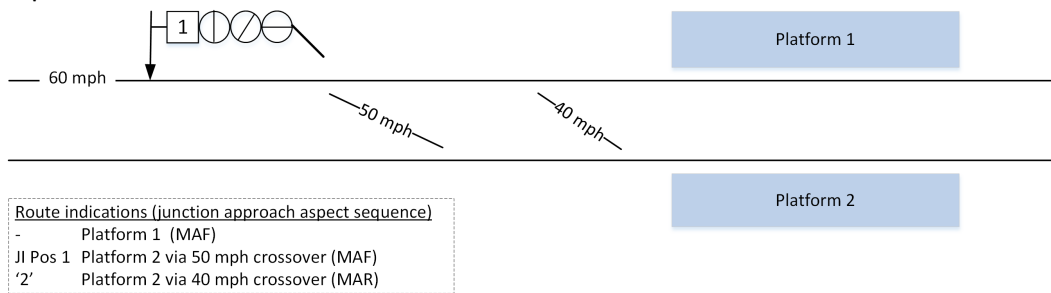

Figure 10: Example of indicating alternative paths using different types of route indications

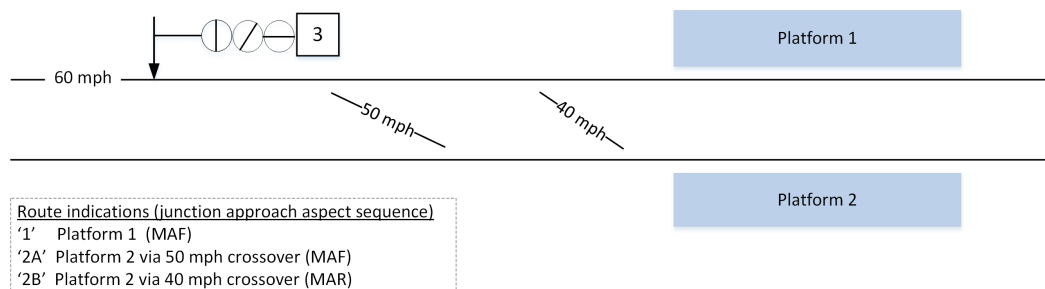

Figure 11: Example of indicating alternative paths using alphanumeric route indications

3.4.6 Banner repeater indications at a diverging junction

- 3.4.6.1 A single-head banner repeater indicator shall be provided with a junction signal only if the junction is signalled using the MAF junction aspect sequence (free junction signal aspect), the MAR junction aspect sequence (junction signal approach controlled from red), or both MAF and MAR.
- 3.4.6.2 Where provided, a single-head banner repeater indicator shall show the banner-ON indication with the junction signal proceed aspect unless the permissible speed reduction at the diverging junction is no more than 10 mph.
- 3.4.6.3 Where provided, a splitting banner repeater indicator shall show the same indication for more than one diverging signalled route at the junction only if both of the following criteria apply:
 - a) The permissible speed profile on each of those alternative paths is similar, and
 - b) Those paths have similar technical compatibility characteristics.

Rationale

- G 3.4.6.4 Train drivers use the banner-ON indication to interpret that the junction signal is showing the main stop aspect.
- G 3.4.6.5 Train drivers use a splitting banner-OFF indication to interpret that the junction signal is showing a proceed aspect and interpret which line the movement authority (MA) applies to.
- G 3.4.6.6 Conformity with these requirements can be used to control the following driveability hazard precursor listed in section 1.3.2:

Poor interpretability

Guidance on application of banner repeater indicators

- G 3.4.6.7 RIS-0737-CCS sets out the process for determining whether a banner repeater is needed on the approach to a junction signal.
- G 3.4.6.8 There are four types of banner repeater, any of which can be provided with a junction signal, subject to conformity with the requirements in this section:

- a) A two-state single-head banner repeater. The indication can be used by a driver to interpret whether the junction signal is showing a main stop aspect or a proceed aspect
- b) A three-state single-head banner repeater. The indication can be used by a driver to interpret whether the junction signal is showing a main stop aspect, a cautionary aspect or a green aspect
- c) A two-state splitting banner repeater. The indication can be used by a driver to interpret whether the junction signal is showing a main stop aspect or a proceed aspect, and whether the MA applies to the principal signalled route or a diverging route
- d) A three-state splitting banner repeater. The indication can be used by a driver to interpret whether the signal is showing a main stop aspect, a cautionary aspect or a green aspect, and whether the MA applies to the principal signalled route or a diverging route.

G 3.4.6.9 Where a single-head banner repeater is provided with a junction signal:

- a) The banner-ON indication is shown when the junction signal is showing the main stop aspect
- b) A banner white-OFF indication can be shown when the junction signal is showing a proceed aspect for either the principal signalled route, or a diverging signalled route if the train can comply with a reduction in permissible speed of 10 mph or less
- c) A banner green-OFF indication can be shown when the junction signal is showing a green aspect for either the principal signalled route, or a diverging signalled route if the train can comply with a reduction in permissible speed of 10 mph or less.

G 3.4.6.10 Where a junction signal has only two main class signal routes, a splitting banner repeater can provide a benefit because it accurately repeats the route-ing information provided at the junction signal. RIS-0758-CCS sets out the requirements for the appearance and meanings of splitting banner repeater indications, which use lateral and vertical displacement of the banner indicator heads to convey route-ing information.

G 3.4.6.11 Where a junction signal is approach controlled from single yellow using junction aspect sequences MAY-FA3, MAY-FA4 or MAY-YY, a splitting banner repeater is used so that a banner OFF indication can be shown when the MA applies to a diverging route.

G 3.4.6.12 Where a junction signal is approach controlled from single yellow for more than one diverging route, the same splitting banner repeater OFF indication can be shown for more than one diverging route if the permissible speed limit differential is 10 mph or less. Driveability assessment is used to confirm that the advance route-ing information is sufficient for the train driver to control the speed of the train within the constraints of the MA available.

3.4.7 Banner junction indications

3.4.7.1 Where provided, a banner junction indicator (BJI) shall show the following indications:

- a) The banner-ON indication when the associated junction signal is showing the stop aspect
- b) The relevant banner-OFF indication and arrow indication when the junction signal is showing a main proceed aspect.

Rationale

- G 3.4.7.2 Train drivers use the banner-ON indication to interpret that the limit of movement authority (limit of MA) is at the junction signal.
- G 3.4.7.3 Train drivers use the combination of the banner-OFF indication and arrow indication to interpret that the junction signal is showing a main proceed aspect and the line the MA applies to.
- G 3.4.7.4 Conformity with this requirement can be used to control the following driveability hazard precursor listed in section 1.3.2:

Poor interpretability

Guidance

- G 3.4.7.5 A BJI is an alternative solution to provision of a splitting banner repeater indicator where a repeater is needed to achieve the required readable distance (RRD) of a main junction signal. It comprises two display elements:
 - a) A banner repeater indicator showing a banner indication, which repeats the junction signal main aspect, and
 - b) A route indicator that shows an arrow indication to repeat the junction indication shown with the main proceed aspect.
- G 3.4.7.6 The process used to determine the application of a BJI is similar to the process set out in RIS-0737-CCS for provision of and positioning a banner repeater indicator.
- G 3.4.7.7 A BJI is capable of providing accurate route-ing information before the junction indication shown at the junction signal can be interpreted. It can provide a benefit where the junction includes multiple diverging lines.
- G 3.4.7.8 The required readable distance (RRD) of a BJI is determined by assessment of the time needed for the train driver to read and interpret the combination of the banner-OFF indication and arrow indication when the junction signal is showing a main proceed aspect.
- G 3.4.7.9 RIS-0758-CCS sets out the requirements for the appearance and meanings of banner repeater indications and arrow indications.

3.5 Requirements for preliminary route indicators

3.5.1 Location of preliminary route indicators

- 3.5.1.1 Where provided in 3-aspect areas, a preliminary route indicator (PRI) shall be located between the junction approach signal and the junction signal.

- 3.5.1.2 Where provided in 4-aspect areas, a PRI shall be located between the junction inner approach signal and the junction signal.
- 3.5.1.3 Where an outer-PRI is provided in 4-aspect areas, it shall be located between the junction outer approach signal and the junction inner approach signal.
- 3.5.1.4 Where provided, a PRI shall be located:
 - a) At a distance equivalent to at least 4s at the permissible speed (or maximum attainable speed) beyond the previous signal, and
 - b) So that the arrow indication is readable when the train reaches the associated junction approach signal.
- 3.5.1.5 A signal showing an indication of signalled route shall not be located within the required readable distance (RRD) of a PRI that is applicable to a different junction.

Rationale

- G 3.5.1.6 The location of a PRI helps drivers to associate the arrow indication with a proceed aspect at the junction signal. An unlit PRI is consistent with a main stop aspect at the junction signal.
- G 3.5.1.7 The minimum distance from the previous signal to the PRI avoids the situation where a driver has to interpret multiple indications of signalled route at the same time.
- G 3.5.1.8 Conformity with these requirements can be used to control the following driveability hazard precursor listed in section [1.3.2](#):

Poor interpretability

Guidance

- G 3.5.1.9 The PRI arrow indication enables the train driver to obtain route-ing information before the train reaches a location where it can be interpreted using a junction cautionary aspect or the junction signal indication of route. The decision to provide a PRI is informed by driveability assessment and an assessment of mis-route-ing risk.
- G 3.5.1.10 The PRI arrow indication is read after the train has passed a signal that would show a cautionary aspect when the limit of MA is at the junction signal. This means that the driver is already preparing for the junction and is able to confirm whether the MA is available and which line beyond the junction it applies to.
- G 3.5.1.11 The decision to implement an outer-PRI on a 4-aspect signalled line is informed by:
 - a) The location of the diverging junction
 - b) The location of the signals on the approach to the junction, and
 - c) The distance needed by the train to stop when an incorrect route is set, taking account of the assessed train speed.
- G 3.5.1.12 The following are examples where a PRI might be beneficial:
 - a) Where a line beyond the junction is prohibited to some trains or rail vehicle types
 - b) Where operation on a non-electrified line beyond the junction includes a traction changeover

- c) Where mis-route-ing a train would increase operational risk; for example, sending a stopping train along a non-platform line
- d) Where alternative signalled routes share the same junction cautionary aspect sequence.

G 3.5.1.13 Figure 12 shows an example where a signal sighting assessment has recommended that providing an inner-PRI would enable a train driver to confirm whether the movement authority (MA) is for a movement towards the depot line before the train reaches a location where the junction signal aspect and junction indication can be read.

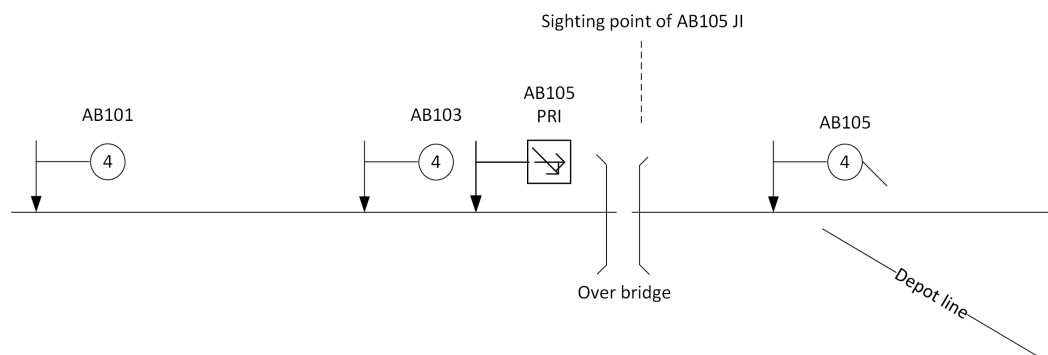

Figure 12: Example of a PRI on the approach to a junction signal

3.5.2 Showing PRI arrow indications

- 3.5.2.1 A preliminary route indicator (PRI) shall show an arrow indication only when:
- a) The junction signal is showing a main proceed aspect, and
 - b) Any signals located between the PRI and the junction signal are showing a main proceed aspect.
- 3.5.2.2 If the conditions for showing an arrow indication are not met, the next signal ahead shall show the signal aspect that is consistent with a limit of movement authority at the junction signal.

Rationale

- G 3.5.2.3 The information provided by the arrow indication complements and is consistent with the (movement authority) MA and route-ing information shown by the junction aspect sequence and junction signal.
- G 3.5.2.4 A PRI is unlit when the junction signal is showing the main stop aspect or when the available MA means that the train will not approach the junction signal.
- G 3.5.2.5 Conformity with these requirements can be used to control the following driveability hazard precursors listed in section 1.3.2:

<p>Poor accuracy of the provided information</p> <p>Poor interpretability</p>

Inconsistent signal aspects and indications presented along the line

Guidance

- G 3.5.2.6 The alignment of PRI arrow indications (position 1 to position 6) mimics the alignment of the junction indication shown at the junction signal and provides the same route-ing information. An arrow indication in position '0' indicates that junction signal is showing a main proceed aspect without a junction indication; this means that the MA applies to the principal line beyond the junction. RIS-0758-CCS sets out further requirements for the appearance and meaning of arrow indications
- G 3.5.2.7 Guidance on the lamp proving of junction indicators is provided in section 2.1.3.
- G 3.5.2.8 The arrow indication can be extinguished at any time after the front of the train has passed the PRI. No operational benefit is gained by providing a separate train detection section as a PRI replacement control.

3.6 Requirements for junction aspect sequences

3.6.1 Types of junction aspect sequences

3.6.1.1 One of the following junction signal aspect sequences shall be shown to the train when a full movement authority (full MA) is available at a diverging junction:

Method	Description
MAR	Junction signal approach controlled from red aspect
MAF	Unrestricted (free) junction signal aspect
MAY-FA3	Junction signal approach controlled from single yellow aspect, with a flashing single yellow aspect at the previous signal
MAY-FA4	Junction signal approach controlled from single yellow, with a flashing 4-aspect sequence at the previous two signals
MAY-YY	Junction signal approach controlled from single yellow, with a double yellow aspect at the previous signal
MAF-SD	Unrestricted (free) junction signal aspect, with a splitting distant proceed aspect(s) at the previous signal(s)

Table 2: Junction aspect sequences

Rationale

- G 3.6.1.2 A greater variety of junction aspect sequences would impact on the development and retention of drivers' route knowledge.
- G 3.6.1.3 Conformity with this requirement can be used to control the following driveability hazard precursor listed in section 1.3.2:

Inconsistent signal aspects and indications presented along the line

Guidance on selecting a junction aspect sequence

- G 3.6.1.4 When a train is approaching a diverging junction and the MA at the junction is towards a diverging line with a reduction in permissible speed greater than 10 mph, over-speed risk using can be mitigated using one of the following methods:
- Applying a junction aspect sequence that enables drivers to obtain the route-ing information before the junction signal aspect and route indication can be interpreted, or
 - Applying the MAR junction aspect sequence.
- G 3.6.1.5 The six options shown in Table 2 are intended to cover the broad range of operational contexts that exist at different locations so that train drivers are able to either take advantage of the relevant permissible speed limit at the junction or stop if an incorrect signalled route is set.
- G 3.6.1.6 The choice of junction approach signal aspect sequence influences:
- When route-ing information is provided to the train driver
 - The accuracy and completeness of the MA information provided before the train reaches the required readable distance (RRD) of the junction signal.
- G 3.6.1.7 The train driving process on the approach to diverging junctions is influenced by:
- Train drivers' route knowledge, including the permissible speed limits on each line
 - Train drivers' understanding of the MA and which signalled route is set at the junction
 - The required train operation on the approach to, and through, the diverging junction.
- G 3.6.1.8 The choice of junction aspect sequence takes account of:
- The method of signalling and type of signalling equipment. For example, only methods MAR and MAF are applicable when making changes to semaphore signalling systems
 - The complexity of the junction layout (including the number of destinations and types of MA on each line)
 - The permissible speed limit profile through the junction area on each line
 - The attainable speeds of trains that use the junction
 - Traffic flows through the junction and the types of trains that use each line
 - The constraints imposed by other junction signals and junction aspect sequences in the same area

g) Any hazards beyond the junction.

G 3.6.1.9 Method MAR applies an approach release from red control to the junction signal aspect. Methods MAY-FA3, MAY-FA4 and MAY-YY apply a delayed 'step-up' from a single yellow aspect. In all of these cases the cautionary aspect sequence is intended to reinforce train drivers' understanding that the train speed needs to be reduced on the approach to the junction signal. The junction signal shows the less restrictive proceed aspect after the train has passed the previous signal and when the driver is assumed to have visibility of the junction signal proceed aspect and indication of signalled route.

G 3.6.1.10 The unrestricted junction signal proceed aspect is shown as soon as possible after the release conditions are met and before the train reaches the AWS magnet so that the AWS indication reflects the junction signal proceed aspect.

G 3.6.1.11 Providing a temporary approach control function is a method of controlling overspeed risk when a temporary speed restriction (TSR) is applicable beyond a junction signal. It can be applied to specific signalled routes if this provides a cost-benefit.

Guidance on signalling alternative approaches to a junction signal

G 3.6.1.12 Where trains can approach a junction signal from alternative lines, the requirement to implement a junction aspect sequence with approach release controls on all approaches might not be necessary and could place an unnecessary constraint on train performance or infrastructure capacity. Driveability assessment is used to confirm that omitting the junction signal approach release control from an approach line can be safely integrated with train operations.

G 3.6.1.13 Approach release controls can be provided for alternative approach lines unless all of the following conditions are applicable:

- The permissible speed limit at the end of the approach line being assessed is lower than the approach line with the highest permissible speed
- The junction signal route indication can be read from where the lower permissible speed limit ends; for example, where the approach line being assessed joins a line with a higher permissible speed
- The permissible speed profile from the approach line being assessed to the diverging line is compatible with the braking performance of all trains that will use the diverging line
- The distance from the end of the lower permissible speed limit to the first stop signal on the diverging line is compatible with the braking performance of all trains that will use the route
- A junction aspect sequence is not needed to control a hazard beyond the junction.

Guidance on control of 'reading-through' risk at a junction signal

G 3.6.1.14 'Reading-through' describes the situation when a driver reads and responds to a signal aspect or indication shown beyond the next signal ahead of the train, which increases the likelihood of a SPAD at a junction signal or overspeed on a diverging line. RIS-0737-CCS sets out requirements and guidance on identifying whether

'reading through' risk is present at a junction signal (signal sighting compatibility factor C13).

G 3.6.1.15 Where junction aspect sequence MAY-FA3, MAY-FA4 or MAY-YY is used, reading-through risk can be mitigated by controlling the first signal beyond the junction to a main stop aspect until the junction signal proceed aspect steps up from the single-yellow to a less restrictive aspect.

G 3.6.1.16 Where reading-through risk at a junction signal is caused by readability of any signal other than the first signal on a diverging line, it is good practice to confirm the effectiveness of the signal overrun risk and SPAD risk mitigation controls provided. Examples of risk mitigation options include:

- a) Preventing the clearance of the signal with the reading-through risk until the front of the train using a diverging line has reached a location where the risk is acceptable
- b) Alternatively, if option a) would adversely impact on train performance on another line, preventing the clearance of the signal causing the reading through risk to a main stop aspect, unless another train has an MA towards that signal. The reading-through controls are designed to prevent the replacement of a signal aspect in front of another train when a diverging signalled route is set at the junction signal.

3.6.2 Showing different junction aspect sequences at the same location

3.6.2.1 Where the lineside signalling system is configured to show more than one junction aspect sequence on an approach to a junction signal, for different diverging routes, the application criteria set out in Table 3 shall apply (Note: the table is intended to be read from left to right).

Applicable to any signalled route at the junction	Applicable to another signalled route at the junction				
	MAR	MAF	MAY-FA3 or FA4	MAY-YY	MAF-SD
MAR: Junction signal approach controlled from red aspect (R)	yes	yes	yes	yes	yes
MAF: Unrestricted (free) junction signal aspect	yes	yes	yes	yes	no
MAY-FA3 (or FA4): Junction signal approach controlled from single yellow aspect (Y), with a flashing aspect sequence at the previous signal(s)	yes	yes	yes #1 #2	no	no
MAY-YY: Junction signal approach controlled from a single yellow aspect (Y), with a double yellow aspect (YY) at the previous signal	yes	yes	no	yes #1	no

Applicable to any signalled route at the junction	Applicable to another signalled route at the junction				
MAY-SD: Unrestricted (free) junction signal aspect, with a splitting distant proceed aspect(s) at the previous signal(s)	yes	no	no	no	yes #1
#1 - subject to conformity with requirement 3.6.3					
#2 - MAY-FA3 and MAY-FA4 are not implemented with the same signal					

Table 3: Permitted junction approach aspect sequences at the same junction

Rationale

- G 3.6.2.2 The consistent junction signal aspect sequence is used to influence a consistent train driver response and supports the development and retention of route knowledge. The consistent appearance of the junction aspect sequence on the approach to each junction helps drivers to interpret which signalled route is set.
- G 3.6.2.3 Different junction aspect sequences provide route-ing information at different stages on the approach to the diverging junction.
- G 3.6.2.4 Certain combinations are prohibited because the similar cautionary aspects they show could mislead a driver into misinterpreting which line the movement authority (MA) applies to, the extent of the MA and which permissible speed limit applies.
- G 3.6.2.5 Conformity with this requirement can be used to control the following driveability hazard precursors listed in section [1.3.2](#):

Poor interpretability
Inconsistent signal aspects and indications presented along the line
Information is provided at inconsistent times

Guidance

- G 3.6.2.6 The driveability assessment considers the impact on train driving of implementing more than one junction aspect sequence on the same approach to the same junction signal.
- G 3.6.2.7 The MAR sequence is the method of showing a main proceed aspect when the criteria for presenting a less restrictive junction aspect sequence are not met. Additional guidance on applying the MAR junction aspect sequence is provided in [3.7.1](#).
- G 3.6.2.8 RIS-0734-CCS sets out further requirements for applying MAR when a temporary speed restriction (TSR) or emergency speed restriction (ESR) is implemented at a diverging junction.

3.6.3 Showing the same junction aspect sequence for more than one diverging line

3.6.3.1 With the exception of the MAR sequence (junction signal approach controlled from red), the same junction aspect sequence shall be shown for more than one diverging line only if all of the following criteria are met:

- a) The permissible speed limit differential of the diverging lines sharing the same aspect sequence is 10 mph or less at the junction
- b) The diverging line with the higher permissible speed limit is closer to the junction signal than other diverging lines that share the same junction aspect sequence
- c) The diverging lines sharing the same aspect sequence have similar characteristics
- d) Where the diverging lines sharing the same aspect sequence provide alternative paths towards the same destination, the permissible speed limit profiles on each line between the junction signal and the next signal ahead are 10 mph or less.

Rationale

G 3.6.3.2 Train drivers use the junction approach aspect sequence to distinguish which line the movement authority (MA) applies to beyond the junction. In this case, a train driver cannot confirm which signalled route is set until the train reaches the required readable distance (RRD) of the junction signal route indicator.

G 3.6.3.3 If the train driver misinterprets which permissible speed limit applies, the maximum excess train speed is limited to 10 mph.

G 3.6.3.4 If the train reaches the divergence with the higher permissible speed first, this reduces the likelihood of a 10 mph overspeed when the MA applies to the diverging signal route with the lower permissible speed.

G 3.6.3.5 Conformity with this requirement can be used to control the following driveability hazard precursor listed in section 1.3.2:

Poor interpretability

Guidance

G 3.6.3.6 Further requirements and guidance on presenting the same route indication for alternative signal routes are provided in section 3.4.5.

3.7 Requirements for junction aspect sequence: MAR

3.7.1 Delaying the junction signal proceed aspect

3.7.1.1 When the MAR sequence (junction signal approach controlled from red) is used, the junction signal shall show the main stop aspect until the train reaches the location where the junction signal proceed aspect and junction indication can be read together.

Rationale

G 3.7.1.2 The movement authority (MA) and route-ing information for the train movement at the junction is made available only after the train driver is informed to stop at the

junction signal and the train driver has enough information to fulfil the train driving task at the junction. This means that the train driver has enough time (and distance) to conform with the permissible speed beyond the junction signal, on the diverging line.

- G 3.7.1.3 Conformity with this requirement can be used to control the following driveability hazard precursor listed in section 1.3.2:

Insufficient time for the train driver to comply with the operating requirement

Guidance

- G 3.7.1.4 MAR is the most restrictive junction signalling method because it delays the MA on a diverging line until the train driver is informed to stop the train at the junction signal. At some junctions, MAR might be the only suitable junction aspect sequence that provides a compliant solution for that infrastructure layout.
- G 3.7.1.5 MAR might not accurately reflect the actual extent of the MA until the train has reached the required readable distance (RRD) of the junction signal and indication of signalled route. This increases the likelihood of a signal overrun at the junction signal if a train driver anticipates a proceed aspect due to previous experience at that location.
- G 3.7.1.6 Where a junction is configured with a less restrictive junction aspect sequence, MAR provides the means of authorising train movements at the diverging junction when the criteria for showing the less restrictive aspect sequence are not met.

3.7.2 Delaying the junction signal proceed aspect where signal sighting is restricted

- 3.7.2.1 Where the MAR sequence (junction signal approach controlled from red) is shown but signal sighting limitations mean that the junction signal proceed aspect is visible to the train driver before the signal route indication is interpretable, the junction signal shall show the main stop aspect until the train driver can interpret which line the movement authority (MA) applies to.
- 3.7.2.2 Where a non-splitting banner repeater indicator is provided on the approach, the junction signal shall show the main stop aspect until the train has passed the indicator.

Rationale

- G 3.7.2.3 The train driver needs to be able to read the indication of signal route to interpret which line the MA applies to and which permissible speed applies.
- G 3.7.2.4 A non-splitting banner repeater does not provide route-ing information. Showing the banner OFF indication before the train driver can interpret an indication of signalled route would increase the likelihood that the driver misinterprets which line the MA applies to before obtaining the signal route-ing information.
- G 3.7.2.5 Conformity with this requirement can be used to control the following driveability hazard precursors listed in section 1.3.2:

Poor readability Poor interpretability

Guidance

- G 3.7.2.6 Providing one of the following on the approach to the junction signal enables the train driver to interpret which line the MA applies to and therefore the junction signal proceed aspect can be shown before the route indication is fully visible:
- a) A splitting banner repeater indicator, or
 - b) A banner junction indicator (BJI).
- G 3.7.2.7 The actual time that the route indication and junction signal proceed aspect are shown is influenced by any transmission delays within the signal aspect control system.
- G 3.7.2.8 RIS-0737-CCS sets out further requirements for signal sighting assessment at junction signals, providing PRIs and BRIs.

3.8 Junction aspect sequence: MAF

Guidance

- G 3.8.1 The MAF sequence (free junction signal aspect) permits an unrestricted proceed aspect at the junction signal; therefore the train driver does not observe a cautionary aspect sequence that informs a decision to reduce the train speed on the approach to the diverging junction. The train driver interprets which line the movement authority (MA) applies to and the permissible speed limit using only the indication of route at the junction signal. If the train driver misinterprets which signal route is set, the train might exceed the permissible speed limit at the junction.
- G 3.8.2 The following control measures can be applied to reduce the risk of excessive train speed at the junction:
- a) Limiting the permissible speed differential between a diverging line and the line with the highest permissible speed limit to 10 mph or less, or
 - b) Confirming that the maximum attainable speed of trains at the junction is within the permissible speed limit. This can be applied to all trains or to trains that approach the junction signal through a slower speed converging junction.
- G 3.8.3 Risk assessment is used to support a decision to apply MAF controls to diverging signal routes where the permissible speed limit differential exceeds 10 mph.
- G 3.8.4 If the readable distance of the junction signal proceed aspect and junction indication is extended by a splitting banner repeater indicator or a banner junction indicator (BJI), then conformity with this requirement can be achieved using the readability of the repeater indications.
- G 3.8.5 The absence of advance route-ing information is also a factor affecting the consequence of mis-route-ing trains at a diverging junction. Consequences can include incompatibility of a train with the infrastructure on the line and train performance impact.

- G 3.8.6 Providing a preliminary route indicator (PRI) located at least minimum signalling braking distance (MSBD) on the approach to the diverging junction can be used to reinforce the signal route-ing information presented to the train driver and assist in mis-route-ing risk mitigation.
- G 3.8.7 Requirement 3.1.3 is also relevant to controlling the likelihood of a train exceeding the permissible speed limit on a diverging route.

3.9 Requirements for junction aspect sequences: MAY-FA3 & MAY-FA4

3.9.1 Showing the flashing single yellow aspect

- 3.9.1.1 A signal shall change to show a flashing single yellow aspect (FY) only if no train is located within the required readable distance (RRD) of that signal.

Rationale

- G 3.9.1.2 The train driver needs enough time to interpret the FY before the train passes the signal.
- G 3.9.1.3 Conformity with this requirement can be used to control the following driveability hazard precursor listed in section 1.3.2:

Poor interpretability

Guidance

- G 3.9.1.4 Flashing aspect sequences were developed in the 1970s as a method of achieving higher train speeds at higher speed diverging junctions, where the alternative of using MAR (junction signal approach controlled from red) was too restrictive and the criteria for using MAF (free junction signal aspect) or MAY-YY (junction signal approach controlled from a single yellow aspect with a double yellow aspect at the previous signal) were not met.
- G 3.9.1.5 The flashing aspect(s) accurately reflects the main proceed aspect for a diverging move at the junction; however, it does not indicate the actual extent of movement authority (MA) or the direction of the divergence. The driver is able to obtain this information only when the train is within the RRD of the junction signal aspect and signal route indication.
- G 3.9.1.6 Because flashing aspect sequences are generally applied to diverging signal routes with higher permissible speed limits, the likelihood of a train exceeding the permissible speed limit would increase if the junction turnout speed is less than train drivers expect. Table 4 sets out permissible speed limit criteria typically applied to control this.

Permissible speed approaching the diverging junction	Permissible speed at the point of divergence
80 mph – 125 mph	40 mph or greater
40 mph – 80 mph	25 mph – 40 mph

Table 4: Permissible speed profiles typically applied to MAY-FA3 and MAY-FA4

- G 3.9.1.7 Risk assessment informs a decision to show a flashing aspect sequence for a junction with a lower permissible speed limit at the divergence. The following are examples of locations where this might provide a benefit:
- Providing a flashing aspect sequence on a high-speed passenger line for an MA towards a non-passenger line can support the driveability of freight trains and minimise the time taken for them to clear the junction. In this case, the flashing aspect sequence is only shown to non-passenger trains. The permissible speed limit applicable to passenger trains is not relevant to the assessment
 - Where showing a flashing aspect sequence on a steep climbing gradient would improve operational performance or save energy.
- G 3.9.1.8 Buffer stop collision risk mitigation includes not showing a flashing aspect sequence for an MA towards a bay or terminal platform.
- G 3.9.1.9 It is good practice to assess the signal overrun risk (SPAD risk) at the first signal on the diverging line because:
- The single yellow aspect (Y) shown by the junction signal indicates the requirement for the train to stop at the first signal beyond the junction, even though this is not always the case. If train driving experience leads to an expectation that the junction signal always steps up to a less restrictive aspect, a train driver might become conditioned to not respond to the Y at the junction signal
 - If the reduction in train speed necessary to comply with the permissible speed limit at the junction is not compatible with the stopping distance from the junction to the first stop signal on the diverging line, greater reliance is placed on drivers' route knowledge to understand the speed reduction necessary to comply with the limit of MA when the junction signal continues to show the Y.
- G 3.9.1.10 Where the first signal on the diverging line protects another junction, a level crossing, a station platform or a signal section that is assessed to be frequently occupied by another train, the MAR junction aspect sequence can be shown when the first signal on the diverging line is showing a main stop aspect. If this solution would be too restrictive, SPAD risk assessment is used to confirm that SPAD risk is acceptable because either:
- The first signal on the diverging line usually clears to a proceed aspect before the train reaches that signal, or
 - Most trains stop on the approach to the first signal on the diverging line for another reason (such as at a station), irrespective of which signal aspect is shown.
- G 3.9.1.11 The MAR sequence is shown if requirement [3.9.1.1](#) is not met.

3.9.2 MAY-FA3 aspect sequence controls

- 3.9.2.1 The MAY-FA3 sequence (junction signal approach controlled from single yellow with a flashing yellow aspect at the previous signal) shall show the following signal aspects:
- At the junction approach signal, the 3-aspect junction approach flashing caution (FY), and
 - At the junction signal, the 3-aspect caution (Y) with the relevant junction indication, until the train reaches the location where the junction signal aspect and junction indication can be read together.

Rationale

- G 3.9.2.2 In 3-aspect signalling areas, the FY is shown at least minimum signalling braking distance (MSBD) from the junction signal. This means that the train driver will always have enough time (and distance) to conform with the permissible speed limit on the diverging line. The junction signal proceed aspect steps up from Y to a less restrictive aspect when the train driver has enough information to inform the train driving task at the junction.
- G 3.9.2.3 Conformity with this requirement can be used to control the following driveability hazard precursor listed in section 1.3.2:

Insufficient time for the train driver to comply with the operating requirement

Guidance

- G 3.9.2.4 The MAY-FA3 aspect sequence is configured so that the train driver can:
- Read the FY to interpret that a full movement authority (full MA) is available on a lower speed diverging route and then
 - Read the main proceed aspect and junction indication to interpret the extent of MA that is actually available and the line to which it applies. The driver does not have to read the approach-controlled Y shown by the junction signal.
- G 3.9.2.5 Figure 13 shows an example of this requirement where the junction indicator cannot be read before the train passes the signal presenting the FY.

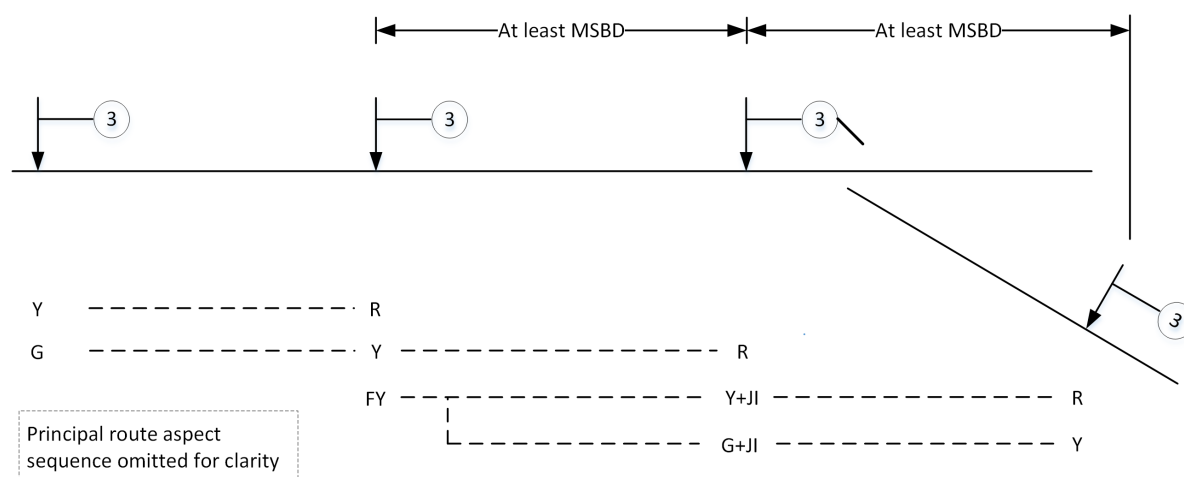

Figure 13: A typical MAY-FA3 aspect sequence for a right hand diverging junction

3.9.3 MAY-FA4 aspect sequence controls

- 3.9.3.1 The MAY-FA4 sequence (junction signal approach controlled from 4-aspect single-yellow with a flashing 4-aspect signal at the previous two signals) shall show the following signal aspects:
- At the junction outer approach signal, either the 4-aspect outer junction approach flashing caution (FYY), or the 4-aspect first caution (YY)
 - At the junction inner approach signal, the 4-aspect inner junction approach flashing caution (FY), and
 - At the junction signal, the 4-aspect single yellow caution (Y) with the relevant junction indication, until the train reaches the location where the junction signal proceed aspect and junction indication and can be read together.

Rationale

- G 3.9.3.2 In 4-aspect signalling areas, the junction outer approach signal is positioned at least minimum signalling braking distance (MSBD) from the junction signal (See Figure 14). This means that if the FYY or YY aspect is shown, the train driver will always have enough time (and distance) to conform with the permissible speed limit at the junction.
- G 3.9.3.3 The distance from the junction inner approach signal to the junction signal influences how much time the train driver has to regulate the speed of the train on the approach to the junction. If the train driver has correctly responded to the FYY or YY aspect at the previous signal, the distance from the FY to the junction should always provide enough distance for the train to comply with the permissible speed limit and the limit of movement authority (limit of MA) at the first signal on the diverging line.
- G 3.9.3.4 The junction signal proceed aspect steps up from Y to a less restrictive aspect when the train driver has enough information to inform the train driving task at the junction.
- G 3.9.3.5 Conformity with this requirement can be used to control the following driveability hazard precursor listed in section 1.3.2:

- c) A FY presented at two consecutive signals. Each flashing aspect is always shown only once in a sequence.

3.9.4 Co-acting signals that show flashing aspects

- 3.9.4.1 When shown by a co-acting signal, a flashing aspect shall flash in synchronism throughout the primary and co-acting signal heads.

Rationale

- G 3.9.4.2 Train drivers need to be able to reliably read and interpret the flashing aspect to understand which line beyond the junction the movement authority (MA) applies to. Asynchronous presentation of a flashing aspect in primary and co-acting signal heads could mislead a driver into misinterpreting the information as applicable to adjacent lines.

- G 3.9.4.3 Conformity with this requirement can be used to control the following driveability hazard precursor listed in section 1.3.2:

Poor interpretability

Guidance

- G 3.9.4.4 A signal sighting assessment is used to confirm that a flashing aspect presented by a co-acting signal is interpretable and consider whether alternative signalling arrangements would reduce the likelihood of misinterpretation of the signal route that is set.
- G 3.9.4.5 Further requirements for co-acting signals are set out in RIS-0737-CCS and RIS-0758-CCS.

3.10 Requirements for junction aspect sequence: MAY-YY

3.10.1 Application of MAY-YY

- 3.10.1.1 The MAY-YY sequence (junction signal approach controlled from single yellow with a double yellow aspect at the previous signal) shall be shown only if all of the following criteria apply:

- a) The route-ing information is provided using a junction indicator
- b) The readability of the junction signal proceed aspect and indication of signal route are the same
- c) The distance from the junction to the first stop signal on each line beyond the junction is equal or greater than the deceleration distance needed for trains to stop at those signals.

Rationale

- G 3.10.1.2 MAY-YY provides drivers with only one opportunity to obtain route-ing information. Train drivers need to be able to read and interpret the junction signal aspect and junction indication together to correctly interpret which line the MA applies to.

- G 3.10.1.3 The required position of stop signals relative to the junction provides enough time (and distance) for the train driver to control the speed of the train to conform with the permissible speed limit at the junction and the limit of movement authority (limit of MA) at the first stop signal beyond the junction, whichever signal route is set.
- G 3.10.1.4 Conformity with this requirement can be used to control the following driveability hazard precursors listed in section 1.3.2:

Poor interpretability
Insufficient time for the train driver to comply with the operating requirement

Guidance

- G 3.10.1.5 MAY-YY is typically used to optimise junction capacity in complex areas where there is an intensive but relatively low speed train service. MAY-YY can provide cost benefit through operational efficiencies where MAF (free junction signal aspect) cannot be applied, MAR (junction signal approach controlled from red) would be too restrictive and a flashing aspect sequence or junction splitting distant sequence would be unnecessarily complicated.
- G 3.10.1.6 MAY-YY is typically used where the permissible speed limit differential at the junction is more than 10 mph and the junction signal is positioned so that the deceleration distance is less than the minimum readable distance (MRD) to the junction.
- G 3.10.1.7 The double yellow aspect (YY) accurately reflects the availability of an MA on a diverging line at the junction; however, it does not indicate the actual extent of MA, which signal route is set or the direction of the divergence. The driver is able to obtain this information only when the train has reached the required readable distance (RRD) of the junction signal aspect and junction indication.
- G 3.10.1.8 The following risk mitigation measures can be applied to control the likelihood of operational incidents associated with MAY-YY:
- The permissible speed limit approaching the junction and on any line beyond the junction is 60 mph or less
 - The maximum differential between all permissible speed limits on any line beyond the junction is 30 mph or less
 - Position the junction signal so that dimension 'D1' plus the MRD of the signal and junction indicator is compatible with deceleration to the permissible speed on the diverging line
 - Position the signals so that Figure 15 dimension 'D2' is compatible with a train decelerating to stop at the first signal on the principal signal route not exceeding the permissible speed limit on the diverging line by more than 10 mph. If the train driver misinterprets that the MA applies to the higher speed line when the diverging signal route is set, the excess train speed should not result in a derailment
 - Position the signals so that Figure 15 dimension 'D3' is compatible with a train decelerating to stop at the first signal on the diverging line not exceeding the permissible speed limit. If the train driver misinterprets that the MA applies to a

diverging line when the principal signal route is set, the train should be capable of stopping at the first signal beyond the junction

- f) Confirm that the train consists operating on each line result in a consistent train braking requirement to comply with the permissible speed limit at the junction. Irrespective of the train being driven, the train driving task is similar in order to comply with the permissible speed limit at the junction
- g) Confirm that all trains approaching the junction are compatible with all lines beyond the junction. A train might not be able to stop at the junction signal when the wrong signal route is set.

G 3.10.1.9 A preliminary route indicator (PRI), banner junction indicator (BJI) or splitting banner repeater indicator can be used to provide an earlier indication of the line on which the MA applies.

G 3.10.1.10 RIS-0737-CCS sets out further requirements for signal sighting assessment at junction signals and preliminary route indicators, and guidance on when it is acceptable to use signal route indication visibility to achieve the RRD.

3.10.2 Delaying the less restrictive proceed aspect

3.10.2.1 The MAY-YY sequence (junction signal approach controlled from a single yellow aspect with a double yellow aspect at the previous signal) shall show the following signal aspects:

- a) At the junction approach signal, the 4-aspect first caution (YY), and
- b) At the junction signal, the 4-aspect single yellow caution (Y) with the relevant junction indication, until the train reaches the location where the junction signal proceed aspect and junction indication can be read together.

Rationale

G 3.10.2.2 The position of the YY means that the train driver will always have enough time (and distance) to conform to the permissible speed limit at the junction. A less restrictive junction signal aspect is shown only after the train driver has had time to respond to the YY and when the train driver has enough information to inform the train driving task at the junction.

G 3.10.2.3 Conformity with this requirement can be used to control the following driveability hazard precursors listed in section 1.3.2:

Inconsistent signal aspects and indications presented along the line
Insufficient time for the train driver to comply with the operating requirement

Guidance

G 3.10.2.4 The MAY-YY aspect sequence is configured so that the train driver can:

- a) Read the YY to interpret that a full movement authority (full MA) is available at the junction, and then

- b) Read the main proceed aspect and junction indication to interpret the extent of MA that is actually available and the line to which it applies. The driver does not have to read the Y shown by the junction signal because the train should be slowing down in response to the YY shown at the previous signal.

G 3.10.2.5 Figure 15 illustrates a typical MAY-YY aspect sequence (incorporating the option of a preliminary route indicator (PRI) to show an early indication of signal route). Dimension 'D1' is relevant if the driver interprets that the MA is along the wrong line. Further guidance on dimensions 'D2' and 'D3' is provided in section 3.10.1.

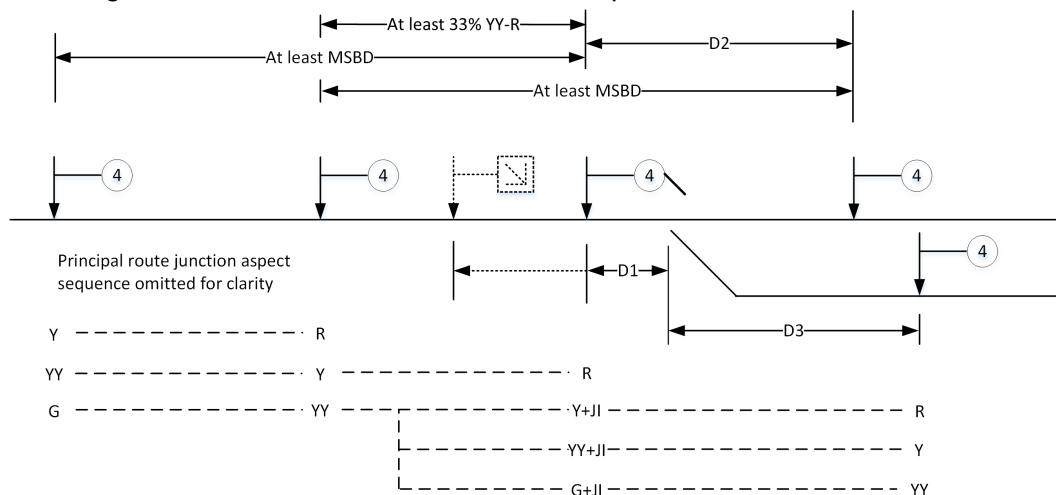

Figure 15: A typical MAY-YY aspect sequence

G 3.10.2.6 Current practice for applying MAY-YY on the GB mainline railway is to show the less restrictive junction signal proceed aspect before the approaching train reaches the AWS magnet, unless another condition means that a proceed aspect cannot be displayed. Further application requirements for AWS track equipment are set out in RIS-0775-CCS.

3.11 Requirements for junction aspect sequence: MAF-SD

3.11.1 Application of MAF-SD

3.11.1.1 A signal shall change to show a splitting distant proceed aspect only if no train is located within the required readable distance (RRD) of that signal.

Rationale

G 3.11.1.2 The train driver needs enough time to read and interpret the indication of signal route before the train passes the junction approach signal.

G 3.11.1.3 Conformity with this requirement can be used to control the following driveability hazard precursor listed in section 1.3.2:

Poor interpretability

Guidance

- G 3.11.1.4 MAF-SD can be beneficial to driveability because it provides a positive and unrestricted indication of the movement authority and which line it applies to.
- G 3.11.1.5 The decision to provide a splitting distant aspect sequence is informed by the implementation of lamp proving controls and the availability of space to accommodate a splitting distant signal.
- G 3.11.1.6 In 3-aspect signalling areas, the splitting distant aspect is shown at least minimum signalling braking distance (MSBD) from the junction signal, which means that the train driver should have enough time to stop the train before the junction if an incorrect signal route is set.
- G 3.11.1.7 RIS-0758-CCS and RIS-0737-CCS set out further requirements relevant to splitting distant signals and signal aspects. RIS-0734-CCS provides further guidance on the indication of permissible speeds at diverging junctions.
- G 3.11.1.8 The MAR sequence (junction signal approach controlled from red) can be presented if the conditions necessary for presenting a junction splitting distant aspect sequence are not met.

3.11.2 MAF-SD aspect sequence controls in 3-aspect signalling areas

- 3.11.2.1 In 3-aspect signalling areas, the MAF-SD sequence (free junction signal aspect with a splitting distant proceed aspect at the previous signal) shall show the following signal aspects:
 - a) At the junction approach signal, the splitting distant aspect relevant to the signal route that is set, and
 - b) At the junction signal, the main proceed aspect and, when the MA applies to a diverging line, the junction indication.

Rationale

- G 3.11.2.2 The driver uses the splitting distant aspect to interpret which line the movement authority applies to and which permissible speed applies before the train reaches a location where the junction signal and route indication can be interpreted.
- G 3.11.2.3 Conformity with this requirement can be used to control the following driveability hazard precursors listed in section 1.3.2:

Inconsistent signal aspects and indications presented along the line
Insufficient time for the train driver to comply with the operating requirement

Guidance

- G 3.11.2.4 Figure 16, Figure 17 and Figure 18 show typical examples of the signal aspects presented by splitting distant signals.

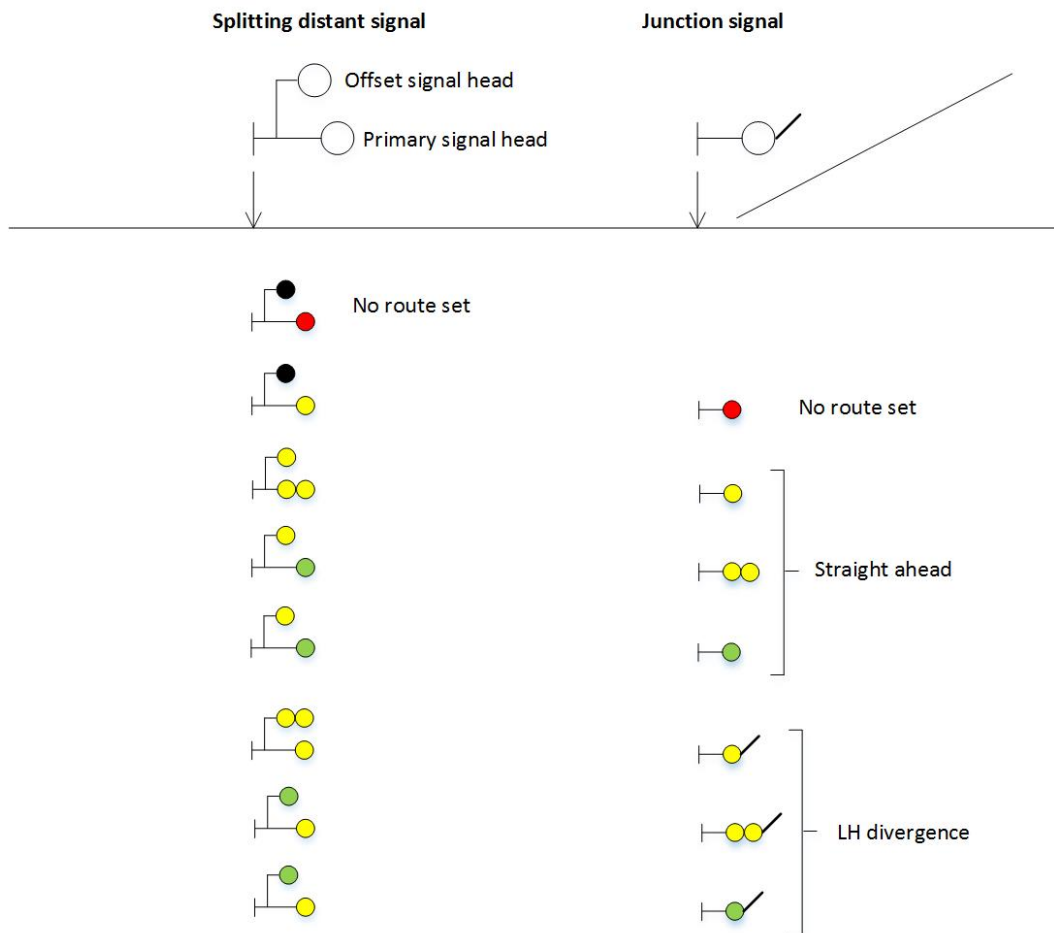

Figure 16: Splitting distant signal positioned on the left-hand side of the line with a left-hand diverging junction

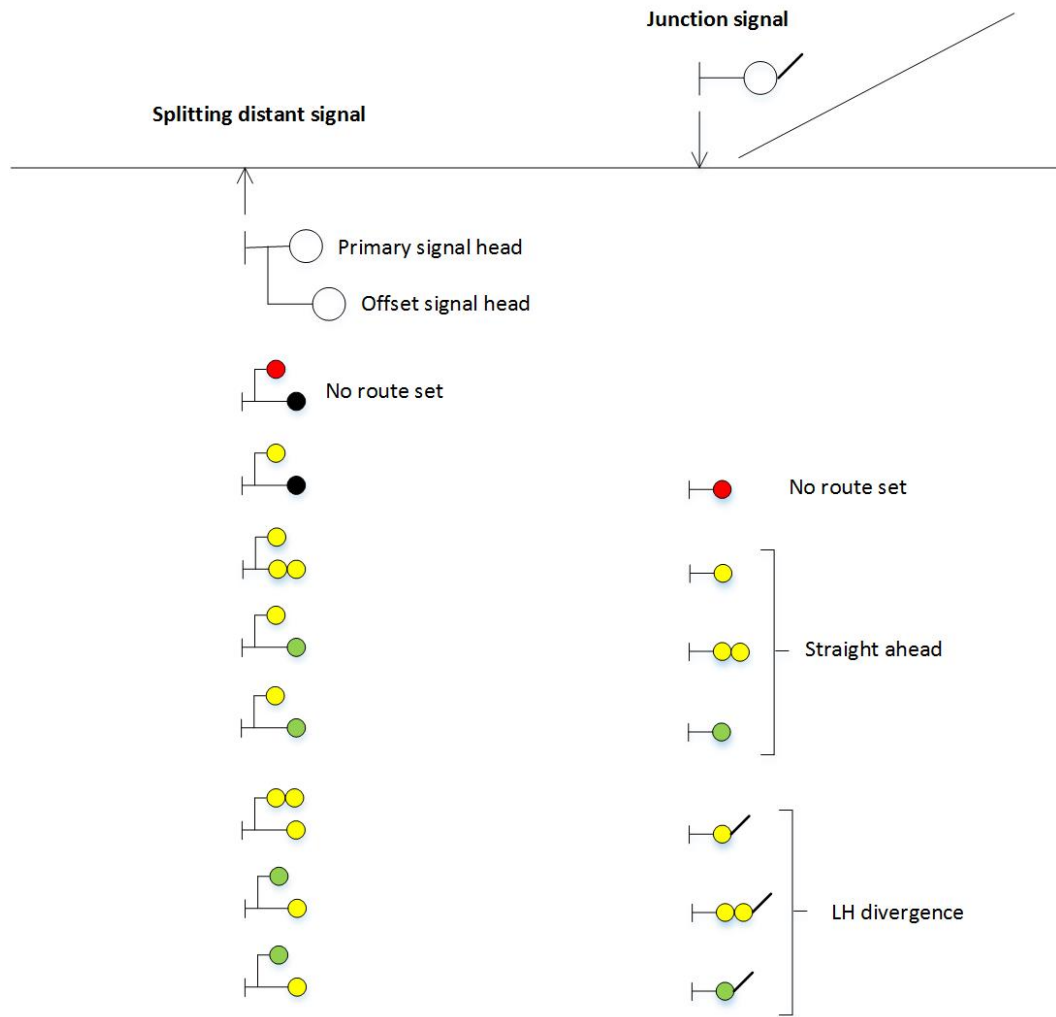

Figure 17: Splitting distant signal positioned on the right-hand side of the line with a left-hand diverging junction

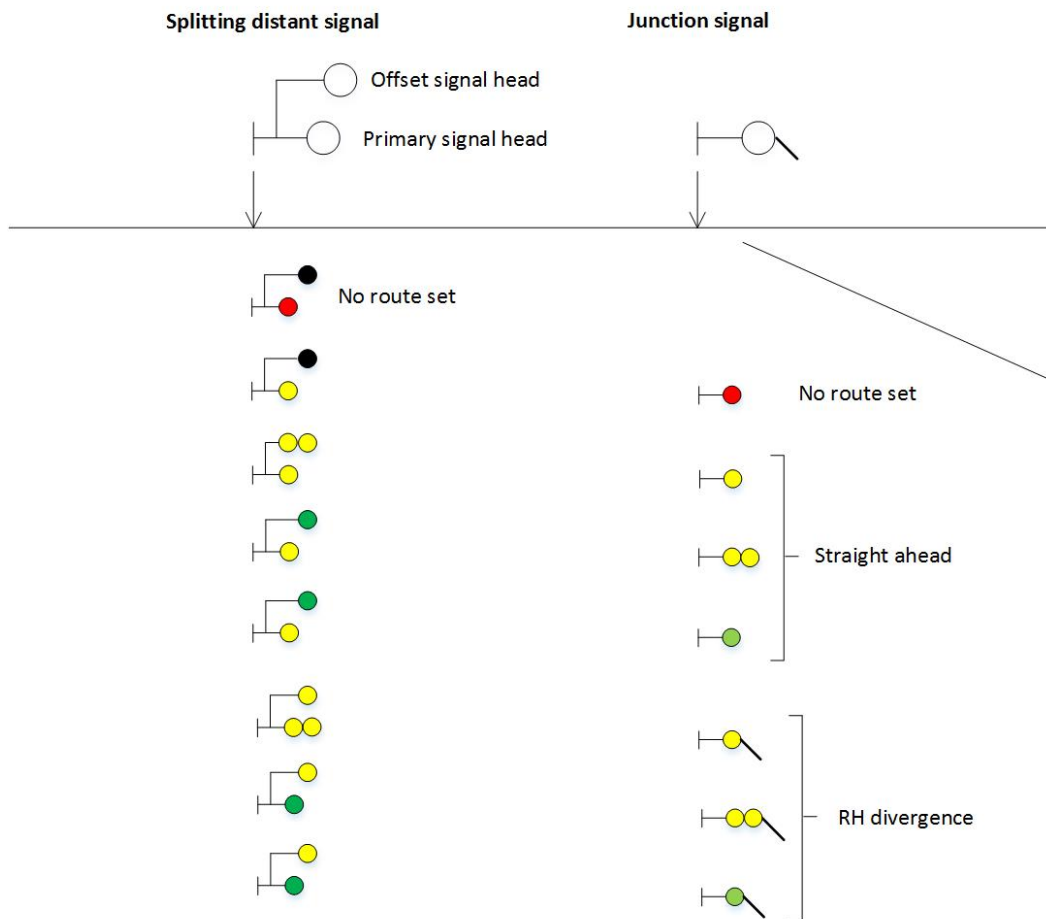

Figure 18: Splitting distant signal positioned on the left-hand side of the line with a right-hand diverging junction

3.11.3 MAF-SD aspect sequence controls in 4-aspect signalling areas

3.11.3.1 In 4-aspect signalling areas, the MAF-SD sequence (free junction signal aspect with a splitting distant proceed aspect at the previous signal) shall show the following signal aspects and indications:

- At the junction outer approach signal, the proceed signal aspect relevant to the aspect sequence through the junction
- At the junction inner approach signal, the splitting distant aspect relevant to the route that is set, and
- At the junction signal, the main proceed aspect and, when the MA applies to a diverging line, the junction indication.

Rationale

- G 3.11.3.2 If the splitting distant signal is positioned at least deceleration distance from the junction, the train driver will always have enough time (and distance) to conform with the permissible speed limit at the junction.
- G 3.11.3.3 Conformity with this requirement can be used to control the following driveability hazard precursors listed in section 1.3.2:

Inconsistent signal aspects and indications presented along the line
Insufficient time for the train driver to comply with the operating requirement

Guidance

- G 3.11.3.4 An additional indication of signal route might be needed to conform with the requirement set out in 3.1.3. Options for meeting this requirement include:
- An outer splitting distant signal;
 - A preliminary route indicator (PRI).
- G 3.11.3.5 The PRI is useful as a mis-route-ing risk mitigation measure. The chosen solution is informed by a risk assessment, which takes account of:
- The deceleration distance available from the junction inner approach signal
 - The better readability performance of a signal aspect compared with a PRI
 - The likelihood of a train driver misinterpreting which signal route is set at the junction, and
 - The consequence of a train passing the junction signal when an incorrect signal route is set.
- G 3.11.3.6 Section 3.5.1 sets out the requirement for locating a PRI relative to a colour light signal.
- G 3.11.3.7 Figure 19 illustrates a typical MAF-SD junction aspect sequence, including the options to provide advance route-ing information in 4-aspect signalling areas.

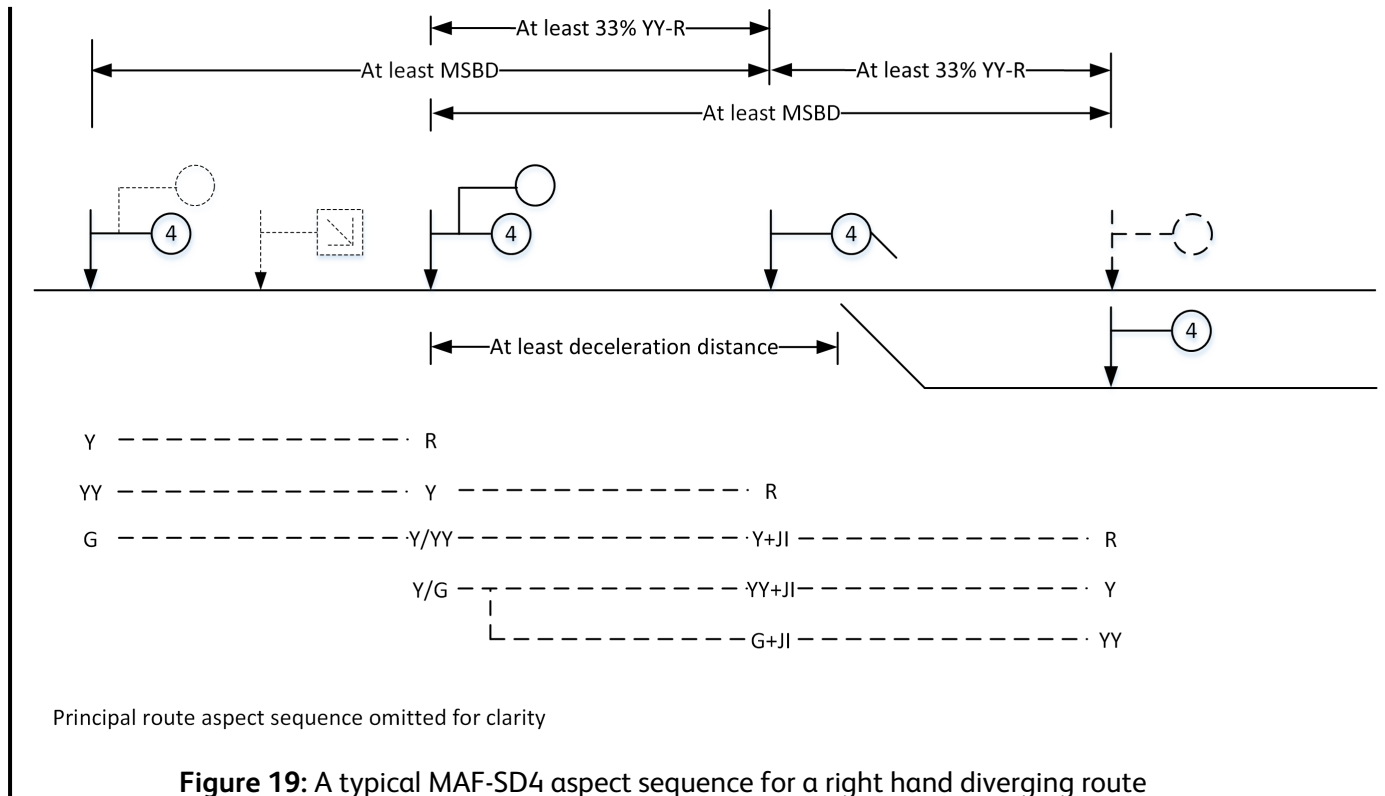

Part 4 Requirements for System Status Indications

4.1 Requirements for signal OFF indications

4.1.1 Showing a signal OFF indication

4.1.1.1 The signal OFF indication shall be shown only when the repeated signal is being controlled to show a proceed aspect.

Rationale

G 4.1.1.2 The train dispatch process and train dispatch system are used to confirm that station duties are complete and that it is safe for the train to leave the station.

G 4.1.1.3 Dispatching a train that does not have a movement authority (MA) sufficient for a train movement beyond the station platform increases the likelihood of a signal overrun whilst the train remains within the platform confines and could increase the level of risk at the platform-train interface.

G 4.1.1.4 Conformity with this requirement can be used to control the following driveability hazard precursor listed in section 1.3.2:

Provided information cannot be relied upon

Guidance

G 4.1.1.5 A signal OFF indication is a means of indicating that the train has an MA where the signal aspect cannot be read from the train dispatch position. The position of the indicator is confirmed using a signal sighting assessment.

G 4.1.1.6 The signal OFF indication only provides sufficient information for the dispatcher to interpret that the train has an MA. It does not convey information about the type or extent of the MA.

G 4.1.1.7 Where the signal OFF indication repeats the aspect presented by a mid-platform signal, the OFF indication is shown only when all other stop signals that need to show a proceed aspect for the train to leave the station platform are also OFF. This reduces the likelihood that:

- a) The departing train will overrun the limit of MA at the platform exit signal
- b) The departing train will stop again within the platform after it has started to move.

G 4.1.1.8 Where the signal OFF indication repeats the aspect presented by a platform end signal, and there is also a mid-platform signal, the train dispatch system design takes account of the potential train dispatch risk of illuminating all signal OFF indicators along the platform; for example, when two short trains are occupying the separate signal sections but only the front train is being dispatched.

4.2 Requirements for locally monitored infrastructure indications

4.2.1 Showing locally monitored infrastructure indications

4.2.1.1 Where a line incorporates locally monitored infrastructure, the relevant coloured light indication shall be continuously shown on each signalled approach to the following infrastructure features:

- a) Locally monitored facing points
- b) Locally monitored trailing points that are not fitted with a trailable point mechanism
- c) A locally monitored level crossing
- d) TPWS track equipment associated with a stop board.

Rationale

G 4.2.1.2 The indication completes the information needed by the train driver to confirm the location of the locally monitored infrastructure and understand what action, if any, is necessary before the train passes the indicator.

G 4.2.1.3 Conformity with this requirement can be used to control the following driveability hazard precursor listed in section 1.3.2:

Information provided by the signalling system is not complete

Guidance

G 4.2.1.4 The coloured light indications provide some of the information that train drivers need to comply with the operating requirements at locally monitored infrastructure, for example, whether or not the infrastructure is set for the train movement. RIS-0758-CCS sets out the requirements for the appearance and meaning of locally monitored system indications.

G 4.2.1.5 A points indicator is provided with locally monitored facing points. The 'facing points set' indication is shown when the points are available for a train movement in the facing direction. The 'infrastructure not operated' indication is shown at all other times. RIS-7707-INS sets out the requirements for train operated points

G 4.2.1.6 Locally monitored points that are used in the trailing direction are fitted with a trailable point mechanism.

G 4.2.1.7 A driver's level crossing indicator is provided with a locally monitored level crossing. The 'level crossing correctly operating' indication provides information that the level crossing has operated to close the road. The 'infrastructure not operated' is shown at all other times, unless a stop board is provided to indicate the limit of movement authority on the approach to the level crossing.

G 4.2.1.8 A TPWS indicator is provided where a TPWS trainstop (TSS) asset is associated with a stop board. The train driver uses the 'TPWS disarmed' indication to confirm that the TPWS system will not stop the train as it passes the stop board. The 'TPWS set' indication is shown at all other times.

- G 4.2.1.9 Further requirements for indications at stop boards are provided in [4.6.1](#) and [4.6.2](#).
- G 4.2.1.10 GERT5021 sets out further requirements relevant to train operated points.
- G 4.2.1.11 RIS-0775-CCS sets out further requirements relevant to TPWS track equipment provided at stop boards.
- G 4.2.1.12 RIS-0792-CCS sets out further requirements relevant to locally monitored level crossings and train crew operated level crossings.

4.2.2 Consistency of locally monitored infrastructure indications

- 4.2.2.1 Where a line incorporates multiple locations where trains operate over locally monitored infrastructure, the order of indications shown for similar operations at each location shall be the same.

Rationale

- G 4.2.2.2 The consistent sequence of indications supports the development and retention of drivers' route knowledge and supports a consistent response.
- G 4.2.2.3 Conformity with this requirement can be used to control the following driveability hazard precursor listed in section [1.3.2](#):

Inconsistent signal aspects and indications presented along the line

Guidance

- G 4.2.2.4 The set of indications shown at each location is influenced by the type of locally monitored infrastructure at each location.
- G 4.2.2.5 The timing of indications at each location is influenced by the operational context. For example, on a line operated using the no signaller token block (NST) system, the train protection and warning system (TPWS) disarmed indication is shown only after the train has stopped and the driver has withdrawn the token from the token instrument.
- G 4.2.2.6 If it is planned to progressively alter or upgrade the locally monitored infrastructure indications along a line, a risk assessment is used to confirm that any inconsistency arising will not result in an unacceptable level of risk.

4.3 Requirements for facing points indications

4.3.1 Showing the 'facing points set' indication

- 4.3.1.1 The 'facing points set' indication shall be shown only when the facing points to which it applies are available for the facing move.

Rationale

- G 4.3.1.2 The train driver uses the 'facing points set' indication to understand that the points are available for the train movement.
- G 4.3.1.3 Conformity with this requirement can be used to control the following driveability hazard precursor listed in section 1.3.2:

Some provided information is not current

Guidance

- G 4.3.1.4 The 'infrastructure not operated' indication is shown at all other times to indicate that the points are not available for a train movement in the facing direction.
- G 4.3.1.5 A points indicator is typically provided on a line fitted with minimum signalling facilities and locally monitored infrastructure.
- G 4.3.1.6 There are two forms of facing points indicator:
- A coloured light indicator that shows a steady yellow light when the points are set and a flashing red light when the points are not set
 - An independent position light that shows the white OFF aspect when the points are correctly set and the red ON aspect when the points are not set. On lines operated using the no-signaller token - remote (NSTR) system, the token denoting the movement authority (MA) is released without confirmation that the passing loop at the end of the section is clear. The position light OFF aspect is used to indicate the permissive nature of the MA beyond the facing points and that the points are correctly set into the loop.
- G 4.3.1.7 The position of the points indicator relative to the facing points is influenced by:
- The requirement for the train to stop before reaching the points if they are not correctly set
 - The requirement for the train driver to check or operate the points if they are not correctly set
 - The risk when the train passes the points indicator when the points are not correctly set.

4.3.2 Provision of fixed distant boards for points indicators

- 4.3.2.1 A fixed distant board shall be provided on each signalled approach to a points indicator.

Rationale

- G 4.3.2.2 The fixed cautionary aspect accurately indicates the requirement for all trains to be prepared to stop at the points indicator if the points are not set. Train drivers expect to observe a cautionary aspect when approaching a points indicator. Consistent application of fixed distant boards supports the retention and development of route knowledge.

G 4.3.2.3 The distinctive appearance of the fixed distant board helps the train driver to distinguish the cautionary aspect and differentiate it from the yellow light points indication. A cautionary aspect presented as a yellow light might mislead the train driver into misjudging the position of the train relative to the facing points and the limit of movement authority.

G 4.3.2.4 Conformity with this requirement can be used to control the following driveability hazard precursors listed in section 1.3.2:

Poor interpretability
Inconsistent signal aspects and indications presented along the line

Guidance

G 4.3.2.5 No guidance is provided.

4.3.3 Distance between the fixed distant board and the points indicator

4.3.3.1 Minimum signalling braking distance (MSBD) shall be available between the fixed distant board and the points indicator to which it applies.

Rationale

G 4.3.3.2 MSBD provides enough time (and distance) for the train driver to stop the train at the points indicator.

G 4.3.3.3 Conformity with this requirement can be used to control the following driveability hazard precursor listed in section 1.3.2:

Insufficient time for the train driver to comply with the operating requirement

Guidance

G 4.3.3.4 The same fixed distant board can also act as the cautionary aspect applicable to the stop signal beyond the facing points.

G 4.3.3.5 Figure 20 illustrates a typical signalling arrangement at locally monitored facing points.

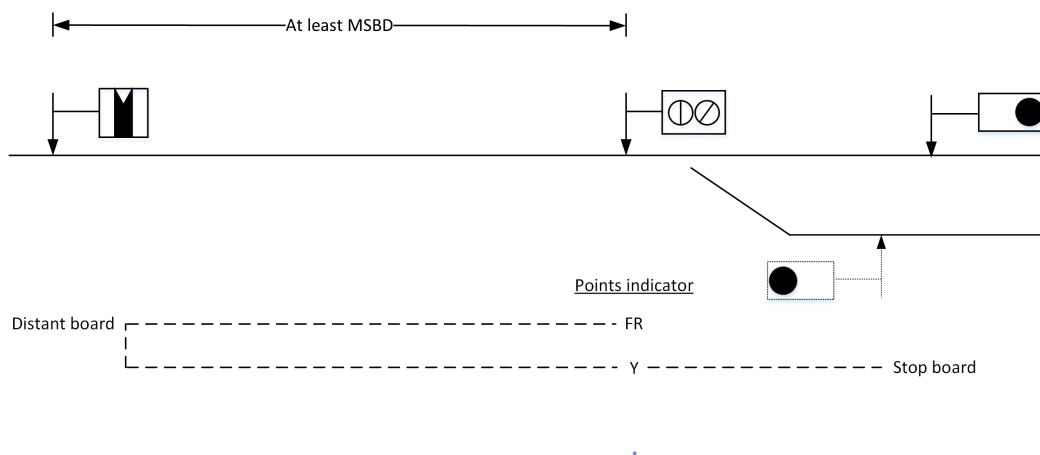

Figure 20: A typical sequence of indications at locally monitored facing points

4.4 Requirement for level crossing operating indications

4.4.1 The 'level crossing operating' indication shall be shown only when the level crossing warning sequence has operated correctly to close the road.

Rationale

G 4.4.2 The train driver uses the 'level crossing operating' indication to understand that the level crossing system is operating correctly.

G 4.4.3 Conformity with this requirement can be used to control the following driveability hazard precursor listed in section 1.3.2:

Some provided information is not current

Guidance

G 4.4.4 Unless a stop signal is provided to protect the level crossing, the 'infrastructure not operated' indication is shown at all other times to indicate that the level crossing is not available for the train.

G 4.4.5 Operating procedures include further requirements relevant to confirmation that the level crossing is clear before the train movement takes place.

4.5 Requirements for barriers up (BU) indication

4.5.1 Position of BU indicators

4.5.1.1 Where provided, the indicator shall be positioned so that the 'barriers up' (BU) indication is shown before the front of the train reaches the required readable distance (RRD) of the BU indicator.

Rationale

- G 4.5.1.2 The RRD provides the train driver with enough time to read and respond to the 'BU' indication without having to reduce the speed of the train.
- G 4.5.1.3 Conformity with this requirement can be used to control the following driveability hazard precursor listed in section 1.3.2:

Poor readability

Guidance

- G 4.5.1.4 The train driver uses the 'Barriers Up' indication to confirm that the level crossing opening sequence has successfully completed after the passage of the train.
- G 4.5.1.5 The indicator position should take account of:
- The time taken for the road opening sequence to be completed after the train has passed over the level crossing
 - The train speed and acceleration performance after the front of the train has passed over the level crossing
 - Maximum train length
 - The RRD of the indicator.
- G 4.5.1.6 RIS-0737-CCS and RIS-0792-CCS sets out further requirements and guidance on providing BU indicators.

4.6 Requirements for TPWS indications

4.6.1 Indications at locally monitored trailing points

- 4.6.1.1 Where train protection and warning system (TPWS) track equipment is provided at a stop board protecting that require to be set before a train movement takes place, all of the following shall apply:
- The stop-board shall show the instruction: 'Obey indications before proceeding'
 - The 'infrastructure not operated' indication shall be continuously shown at the stop board until the points are detected to be set in the position required for the train movement
 - When the points have moved to the required position, the relevant TPWS indication shall supersede the 'infrastructure not operated' indication, and
 - The 'TPWS disarmed' indication shall be shown only when a movement authority (MA) is available for the train to pass the stop board.

Rationale

- G 4.6.1.2 The consistent sequence of displays and indications supports the development and retention of train driver route knowledge. This sequence of indications helps to control the likelihood of a train driver anticipating the MA.

- G 4.6.1.3 The TPWS indication reminds the train driver that TPWS is fitted at the stop board and that if 'TPWS set' is indicated, it might be necessary to use the override function to prevent the train from being stopped.
- G 4.6.1.4 The 'infrastructure not operated' indication informs the train driver's understanding of what action is required to operate the points before the train passes the stop board. The change of indication informs the train driver that the points are available for the train movement.
- G 4.6.1.5 The 'TPWS disarmed' indication is consistent with the availability of a movement authority for the train to pass the stop board.
- G 4.6.1.6 Conformity with this requirement can be used to control the following driveability hazard precursors listed in section [1.3.2](#):

Information provided by the signalling system is not complete
Inconsistent signal aspects and indications presented along the line

Guidance

- G 4.6.1.7 This information may be supplemented by local operating instructions.

4.6.2 TPWS indications where train operated points are associated with a locally monitored level crossing

- 4.6.2.1 Where TPWS track equipment is provided at a stop board protecting locally monitored points and a locally monitored level crossing, the 'level crossing operating' indication shall be shown at the same time as the relevant TPWS indication.

Rationale

- G 4.6.2.2 The consistent sequence of displays and indications supports the development and retention of train driver route knowledge. This sequence of indications helps to control the likelihood of a train driver anticipating the movement authority.
- G 4.6.2.3 The 'level crossing operating' indication informs the train driver's understanding of what action is required before the train passes over the level crossing.
- G 4.6.2.4 Conformity with this requirement can be used to control the following driveability hazard precursors listed in section [1.3.2](#):

Information provided by the signalling system is not complete
Inconsistent signal aspects and indications presented along the line

Guidance

- G 4.6.2.5 If the level crossing has failed but the points have correctly set, the train driver uses the absence of the flashing white light to understand that the level crossing is not working correctly.
- G 4.6.2.6 If the points have failed, the flashing white light + flashing red light combination informs the train driver that the level crossing is operating correctly and that the failure is associated with the points.
- G 4.6.2.7 RIS-0758-CCS sets out further requirements relevant to presenting indication combinations.
-

4.7 Requirements for mechanical trip-cock system indications

4.7.1 Showing the trip-cock test indication

- 4.7.1.1 The 'Trip-cock test' indication shall be shown at the first signal beyond the mechanical trip cock tester until the trip cock is detected to be correctly aligned.

Rationale

- G 4.7.1.2 The 'Trip-cock test' indication provides the result of the trip cock test to the train driver.
- G 4.7.1.3 Conformity with this requirement can be used to control the following driveability hazard precursor listed in section [1.3.2](#):

- Information provided by the signalling system is not complete

Guidance

- G 4.7.1.4 The signal aspect and indication combination is relevant to the procedures for train operations on lines fitted with mechanical train-stop systems.
- G 4.7.1.5 Existing practice on some lines is to control the next stop signal to a stop aspect until the trip cock test has confirmed the trip cock to be correctly aligned. A stop aspect presented with a 'TT' indication helps the train driver to interpret that the trip cock test has failed.
- G 4.7.1.6 GERT8018 sets out further requirements for mechanical trainstop systems.
-

Part 5 Requirements for Train Operating Indications

5.1 Requirement for signs that present written instructions

5.1.1 Requirements for written instructions on lineside signs

5.1.1.1 The written instructions on stop boards and lineside operational signs that show operational information relevant to the train driving task shall be sufficient to remind the user of the operating requirement at that location.

Rationale

G 5.1.1.2 The information provided on the sign supports the development and retention of train driver route knowledge.

G 5.1.1.3 Conformity with this requirement can be used to control the following driveability hazard precursor listed in section 1.3.2:

Information provided by the signalling system is not complete

Guidance

G 5.1.1.4 Stop boards show a fixed stop aspect and written instructions. The written instructions are intended to remind the train driver of the action to be taken before the train passes the stop board.

G 5.1.1.5 Where stop boards are the primary means of designating the limit of movement authority along a line of route, consistency of wording on each stop board can support driveability.

5.2 Requirements for train dispatch system indications

5.2.1 Close door and right away indications

5.2.1.1 The close door (CD) and right away (RA) indications shall be shown only when the corresponding control device has been operated.

5.2.1.2 The 'RA' indication shall be shown only when the train has a movement authority (MA).

5.2.1.3 'CD'/'RA' indication control devices shall be self-restoring.

5.2.1.4 'CD'/'RA' control devices shall be secured so that they can only be operated by train dispatch staff.

Rationale

G 5.2.1.5 The train driver uses the information conveyed by 'CD' and 'RA' indications when preparing to start the train.

G 5.2.1.6 A train should not be dispatched until it has an MA.

- G 5.2.1.7 If the 'CD' or 'RA' indication is shown due to an incorrect or unauthorised operation of the control device, the action of the train driver could result in an unsafe outcome.
- G 5.2.1.8 Conformity with this requirement can be used to control the following driveability hazard precursor listed in section [1.3.2](#):

Provided information cannot be relied upon

Guidance

- G 5.2.1.9 Current practice on the GB mainline railway is to interlock the 'RA' indicator so that it cannot be inadvertently presented with the stop aspect.
- G 5.2.1.10 RIS-8060-CCS sets out further engineering requirements for train dispatch systems.
-

5.3 Requirements for loading / unloading indications

5.3.1 Showing a group of loading / unloading indications

- 5.3.1.1 Where loading / unloading indicators are grouped as a set along a line, all of the indicators in the set shall show the same indication at the same time.

Rationale

- G 5.3.1.2 All of the loading / unloading indicators provide the same information and the same train driver response is required.
- G 5.3.1.3 Conformity with these requirements can be used to control the following driveability hazard precursor listed in section [1.3.2](#):

Some provided information is not current

Guidance

- G 5.3.1.4 Loading / unloading indicators are provided at some locations where the infrastructure manager (IM) co-operates with the railway undertaking (RU) in shunting operations by showing train movement indications in lieu of hand-signalling operations. The indications provide a method of communication between the operator and the train driver.
- G 5.3.1.5 The indications are usually operated from the loading / unloading control location because the position of the train, relative to the facility, is a critical factor.
- G 5.3.1.6 Multiple indicators are provided so that the train driver is always able to view and read an indicator.
-

5.3.2 Loading / unloading indications when a stop aspect is shown

- 5.3.2.1 When a signal aspect is applicable to a line on which loading / unloading indications are used to provide train movement information to the driver, the following shall apply:

- a) The loading / unloading indications shall be lit only when loading / unloading operations are taking place
- b) Any loading / unloading indications beyond the signal shall be extinguished when the stop aspect is presented, and
- c) If the signal is replaced to a stop aspect during loading / unloading operations, all the loading / unloading indicators applicable to the train movement shall show the stop indication.

Rationale

- G 5.3.2.2 The stop aspect indicates the limit of movement authority. The loading / unloading indications are only relevant when the train is authorised to move.
- G 5.3.2.3 The train driver could misinterpret a loading / unloading indication as permission to pass the stop signal.
- G 5.3.2.4 Conformity with this requirement can be used to control the following driveability hazard precursor listed in section [1.3.2](#):

Inconsistent signal aspects and indications presented along the line

Guidance

- G 5.3.2.5 A stop signal is provided to protect the running line beyond the area where loading and unloading operations take place.
-

Definitions

approach controlled aspect	A signal aspect that is maintained at red (MAR) until an approaching train is detected to have passed the previous signal and, where relevant, is assumed to have reached a predetermined distance from the signal or reduction in train speed.
Automatic Warning System (AWS)	A system that gives train drivers in-cab warnings of the approach to signals, reductions in permissible speed and temporary/emergency speed restrictions, and to apply the brakes in the event that a train driver does not acknowledge cautionary warnings given by the system within the specified time. Source: <i>GERT8075</i>
banner junction indicator (BJI)	A lineside signalling asset that shows a lit indication to repeat the main aspect and indication of route shown by the next signal.
banner repeater indicator	A lineside signalling asset that shows a lit indication to repeat the main aspect shown by the next signal.
cautionary aspect sequence	One or more cautionary aspects displayed by the main signals on the immediate signalled approach to the limit of MA.
Common Safety Method for Risk Evaluation and Assessment (CSM RA)	Commission Implementing Regulation (EU) No 402/2013 on the common safety method for risk evaluation and assessment.
distant signal	A signal (not itself a stop signal) capable of displaying a cautionary aspect that informs the driver of the state of the signals or level crossing ahead.
diverging junction	One or more facing points within a signal section where a train can be routed towards alternative lines.
diverging line	Any running line beyond a diverging junction that is not designated as the principal line. This includes lines on which only a shunt movement authority applies.
drive/train driving	The human tasks and processes necessary to control the movement of a train in accordance with operating rules and procedures.
driveability	The ease and reliability that train drivers are able to perform train operations in accordance with rules and procedures, throughout the range of operational and ambient conditions applicable to each train, within the operational context and while performing typical required duties.
driveable	A capability requirement of the lineside signalling system to provide train drivers with the information needed to support their conformity with the train driving rules and procedures.
facing points (FP)	Points where train movements can be routed towards different lines, irrespective of whether or not they constitute part of a diverging junction.

first cautionary aspect	A type of cautionary aspect that provides the first opportunity for a train driver to obtain information about the limit of movement authority ahead of the train. First cautionary aspects include: 4-aspect first caution; 3-aspect caution; outermost distant ON aspect; 4-aspect outer junction approach flashing caution; 3-aspect junction approach flashing caution; splitting distant caution.
full movement authority (full MA)	Authority for a train to proceed into a signal section that is not occupied by other rail vehicles.
hazard precursor	A system failure, sub-system failure, component failure, human error or operational condition which could, individually or in combination with other precursors, result in the occurrence of a hazardous event.
home signal	A stop signal that denotes the exit end of a block or token section, or a limit of a signal section within station limits.
independent shunting signal	A shunting signal that is capable of presenting a stop aspect; includes a signal denoting a limit of shunt.
indication of route	A lineside signalling system display that conveys information about the route set at a diverging junction in the form of either: <ul style="list-style-type: none">a) A signal aspect and route indication combinationb) A combination of semaphore signal aspectsc) A flashing or splitting distant signal aspectd) A preliminary junction indicatione) A splitting banner repeater indication.
indicator	A lineside signalling asset that is capable of displaying a signalling indication.
infrastructure location	A set of lineside signalling infrastructure features defined by the infrastructure manager. Examples include: a junction area; station area; signal box control area.
interpretability	The ease and reliability with which signs, signal aspects and indications can be interpreted by an authorised user throughout the range of operational and ambient conditions applicable to that feature, within the operational context and while performing typical required duties. This ranges from never interpretable to always interpretable.
junction approach signal	A lineside signal that is capable of showing part of a junction signal aspect sequence.
junction indicator (JI)	An indicator provided at a junction signal to inform the driver which way a junction is set, by means of a line of white lights.
junction signal	A signal protecting a diverging junction.
junction signal aspect sequence	The signal aspect(s) and indications used to convey movement authority and route-ing information to the train driver on the signalled approach to a diverging junction.

limit of shunt	A stop aspect that is applicable to shunting movements in the opposite direction to the predominant flow of traffic on a running line.
line	A section of track between two defined locations, with a given identity.
lineside signalling system	A type of signalling system that presents information about movement authorities, route-ing, equipment status, operational information and changes in permissible speeds using lineside displays. The system is configured using the following asset types: <ul style="list-style-type: none">a) signalsb) route indicatorsc) system status indicatorsd) train dispatch system indicatorse) some types of lineside operational sign.
main aspect approach release from red (MAR)	Main junction signal approach controlled from a main stop aspect.
main aspect approach released from yellow (4 Aspect) (MAY-YY)	Main junction signal approach controlled from a 4-aspect single yellow caution (Y), preceded by a 4-aspect first caution.
main aspect approach released from yellow (Flashing 3 Aspect) (MAY-FA3)	Main junction signal approach controlled from a 3-aspect caution, preceded by a 3-aspect junction approach flashing caution.
main aspect approach released from yellow (Flashing 4 Aspect) (MAY-FA4)	Main junction signal approach controlled from a 4-aspect single yellow caution (Y), preceded by a flashing 4-aspect aspect sequence.
main aspect free (MAF)	Unrestricted (free) junction signal aspect sequence.
main aspect free-splitting distance (MAF-SD)	Unrestricted main junction signal aspect, preceded by a splitting distant proceed aspect(s).
main junction signal	A main stop signal that protects a diverging junction and is capable of presenting an indication of route associated with a full MA.
main proceed aspect	Any signal aspect that authorises a non-permissive train movement. The term includes all types of unrestricted proceed aspects and cautionary aspects.
main stop signal	A signal that is capable of presenting a main stop aspect.
minimum signalling braking distance (MSBD)	A signalling system parameter that supports technical compatibility with the specified braking performance of trains when decelerating to a stop after the full service brake is commanded, taking account of:

	<ul style="list-style-type: none">a) The highest train speed when the brake is commandedb) The infrastructure gradient after the brake is commandedc) The required stopping position.
movement authority (MA)	The authority given by a signaller (or ground frame operator), issued via the signalling system to the train driver, which is the authority to move the train within defined limits.
on-sight movement authority (on-sight MA)	Authority for a train to proceed into a signal section that is occupied by a rail vehicle.
non-passenger line	A running line that is not configured for passenger train operations.
passenger line	A running line that is configured for passenger train operations.
permissive train movement	A train movement into a signal section that is occupied by other rail vehicles.
preceding shunt signal	An independent shunting signal located between two main stop signals so that the signal aspect is facing the direction of travel associated with a full movement authority or permissive movement authority.
preceding signal	A stop signal that is cleared to a proceed aspect before the signal it precedes can be cleared. A preceding signal does not denote the end of movement authority.
preliminary route indicator(PRI)	An indicator associated with a junction, giving the driver prior information about which route is set at the junction.
preset signal	A signal that can be cleared by the route set from another signal, for a train movement to pass the signal in the direction to which it applies. When a signal is preset, it is neither at the beginning nor the end of the movement authority.
principal line	The signalled line beyond a diverging junction that has the highest permissible speed of all lines at the junction.
proceed aspect	Any signal aspect that is used to authorise a train movement.
proceed on sight authority (POSA)	A signal aspect for use during lineside signalling failures to instruct the driver to enter a signal section and proceed at such a speed that the train can be stopped short of any obstruction.
required readable distance (RRD)	The readable distance that is maintained for each lineside signalling asset. <p style="text-align: center;">Note: This may be equal or greater than the minimum readable distance (MRD) for that asset.</p>
risk	The combination of the likelihood of occurrence of harm and the severity of that harm (specifically defined in CSM RA regulation as: the frequency of occurrence of accidents and incidents resulting in

	harm (caused by a hazard) and the degree of severity of that harm).
route indicator	A lineside signalling asset that is capable of presenting a route indication.
running line	A line that is shown in Table A of the Sectional Appendix as a passenger line or a non-passenger line.
shunt movement authority (shunt MA)	Authority for a train to proceed for shunting operations.
shunt signal	A stop signal that is capable of presenting a shunt aspect.
siding	A line that is shown in Table A of the Sectional Appendix as a siding.
signal	A lineside signalling asset that presents information concerning movement authorities.
signal route	An interlocking function that establishes and maintains the integrity of a movement authority.
signal section	A portion of line between two consecutive stop signals that apply to train movements in the same direction.
signalled approach	A section of line that is associated with a signalled train movement towards a specific infrastructure feature.
signalled line	A line where movement authorities are issued to train drivers using a signalling system.
signalled route	A path through the track layout layout to which a signalled movement authority applies.
stop aspect	A signal aspect that denotes a limit of MA.
stop signal	A signal that is capable of presenting a stop aspect.
track circuit block (TCB)	A method of working trains in a section of line where safety is ensured by the use of continuous track circuits or other means of train absence detection and without the requirement to visually confirm that trains are complete.
train consist	The total number, type and formation of rail vehicles that make up a train.
train movement specification	A description of the planned train movements.
Train Protection and Warning System (TPWS)	A system mitigating Signals Passed At Danger and non-respect of permissible speeds.

References

The Catalogue of Railway Group Standards gives the current issue number and status of documents published by RSSB. This information is also available from www.rssb.co.uk/railway-group-standards.

RGSC 01	Railway Group Standards Code
RGSC 02	Standards Manual

Documents referenced in the text

GCRT5021	Track System Requirements
GERT8000	Rule Book
GERT8018	Mechanical Trainstop System Interface
GKRT0055	Block System Interface Requirements
GKRT0057	Lineside Signal and Indication Product Design and Assessment Requirements
GKRT0075	Requirements for Minimum Braking and Deceleration Distances
GLRT1210	AC Energy Subsystem and Interfaces to Rolling Stock Subsystem
GLRT1212	DC Conductor Rail Energy Subsystem and Interfaces to Rolling Stock Subsystem

RSSB documents

GEGN8651	Safe Integration of CCS Systems with Train Operations
GKGN0655	Guidance on Block System Interface Requirements
RIS-0009-CCS	Identification of Signalling and Related Equipment
RIS-0036-CCS	CCS System Transitions
RIS-0386-CCS	Rail Industry Standard on Signal Overrun Risk Evaluation and Assessment
RIS-0713-CCS	Lineside Signalling Layout Driveability Assessment Requirements
RIS-0733-CCS	Lineside Operational Signs
RIS-0734-CCS	Signing of Permissible Speeds
RIS-0735-CCS	Signing of Temporary and Emergency Speed Restrictions
RIS-0737-CCS	Signal Sighting Assessment Requirements
RIS-0744-CCS	Permissive Working Risk Assessment
RIS-0758-CCS	Lineside Signal Aspects and Indications
RIS-0775-CCS	AWS and TPWS Application Requirements
RIS-0792-CCS	Level Crossing Operational Interfaces with Trains

Signalling Layout and Signal Aspect Sequence Requirements

Rail Industry Standard
RIS-0703-CCS
Issue: 2 Draft: draft 0.7
Date: September 2023

RIS-2713-RST	System Requirements for the Introduction and Operation of Multi-Mode Rolling Stock
RIS-3782-TOM	Car Stop Markers Provision on Station Platforms
RIS 7707-INS	Switches and Crossings
RIS-8060-CCS	Engineering Requirements for Train Dispatch Systems
T998 (RSSB Research Reports)	Non-standard 4-aspect sequences in colour light signalling areas